

AIRMAX[®]

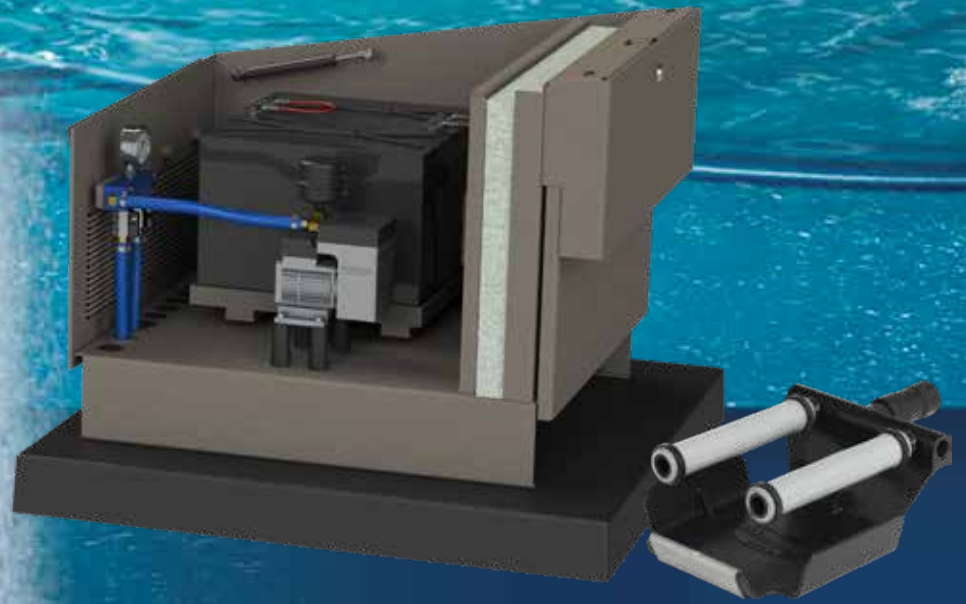

**SolarSeries™ Aeration System
Battery Backup**



OWNER'S MANUAL FOR:

SolarSeries Aeration System

BATTERY BACKUP



TABLE OF CONTENTS

SECTION	PAGE
1 System Components	3-4
2 System Installation	5-15
A.) Tools & Hardware Required	5
B.) Select Location for the EasyMount System	5
C.) Post & Airline Installation	6-7
D.) EasyMount Main Assembly Installation	7-8
E.) Solar Panel Installation & Grounding	9-11
F.) Cabinet Installation & Wiring	12
G.) Connect Airlines	13
H.) Install ProAir Diffusers	13-14
I.) Finalize System Install	14-15
3 Initial Start-Up & Seasonal Operation	16
4 Maintenance	17
5 Troubleshooting	18
6 Replacement Parts	19-20
7 Warranty	21

See Video Instructions of the
Airmax SolarSeries Aeration
System Installation Online



Important Safety Instructions

- Read all assembly and operating instructions carefully.
- To reduce the risk of electric shock, ensure cabinet shut-off switch is in the OFF position when connecting solar panel wiring or conducting any maintenance on the system.
- Repair or exchange of cables/power cords must be carried out by the supplier/manufacturer or certified repair technician.
- This unit has not been evaluated for use in swimming pool areas.
- Airmax is not responsible for equipment damage or failure, losses, injury or death resulting from failure to follow safety precautions, misuse or abuse of equipment.

CAUTION

- Never attempt to modify the system to run on any power source other than the provided Airmax SolarSeries equipment.
- Do not allow anything to rest on the power cords/cables.
- Do not place the cabinet or solar panel mounting system in a direct traffic path.
- Never override or "cheat" any electrical or mechanical devices.
- Never attempt any maintenance function that is not specified in the user manual.

- Never operate the system if unusual noises or odors are detected. Turn the internal and external shut-off switches to the OFF position and call for service.
- This appliance is not intended for use by persons (including children) with reduced physical, sensory, or mental capabilities, or lack of experience and knowledge, unless they have been given supervision or instruction concerning the use of the appliance by a person responsible for their safety.
- Children should be supervised to ensure that they do not play with the appliance.



GROUNDING INSTRUCTIONS – This product must be grounded according to the procedures outlined in the installation section(s). Grounding reduces the risk of electric shock by providing an escape wire for the electric current. This product is supplied with a grounding wire and harnesses with appropriate grounding features.



WARNING

Check with a qualified electrician or technician when grounding instructions are not completely understood or when in doubt as to whether the product is properly grounded. Do not modify the grounding equipment provided with the system.

1. System Components

SolarSeries Aeration Components



SolarSeries Battery Backup Cabinet



SolarSeries SilentAir Diaphragm Compressor

SolarSeries Solar Panel Components

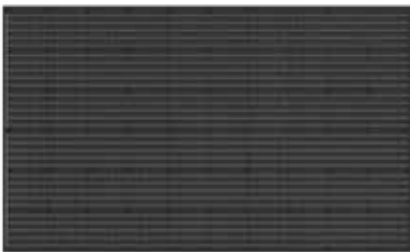

SolarSeries Solar Panels (2)



MC4 Cables (pre-wired leads on back of each panel)

ProAir® 2 Weighted Diffuser



EasySet™ Airline



- Self-Weighted Airline: 5/8" 100' Roll (#510119): Lead-free weighted airline is made of durable PVC composite. Fish hook resistant and kink-free. Use from pond's edge to diffuser.
- Direct Burial Airline (sold separately): 5/8" 100' Roll (#510120) Flexible, yet kink-free. Bury from control panel and compressor to pond's edge when placing the control panel and compressor away from the pond.

*Depending on the type of installation, additional connector kits may be required. See section 6 for connector kits.

Battery (x2), and MPPT Controller



Airmax EasyMount™ Assembly Components

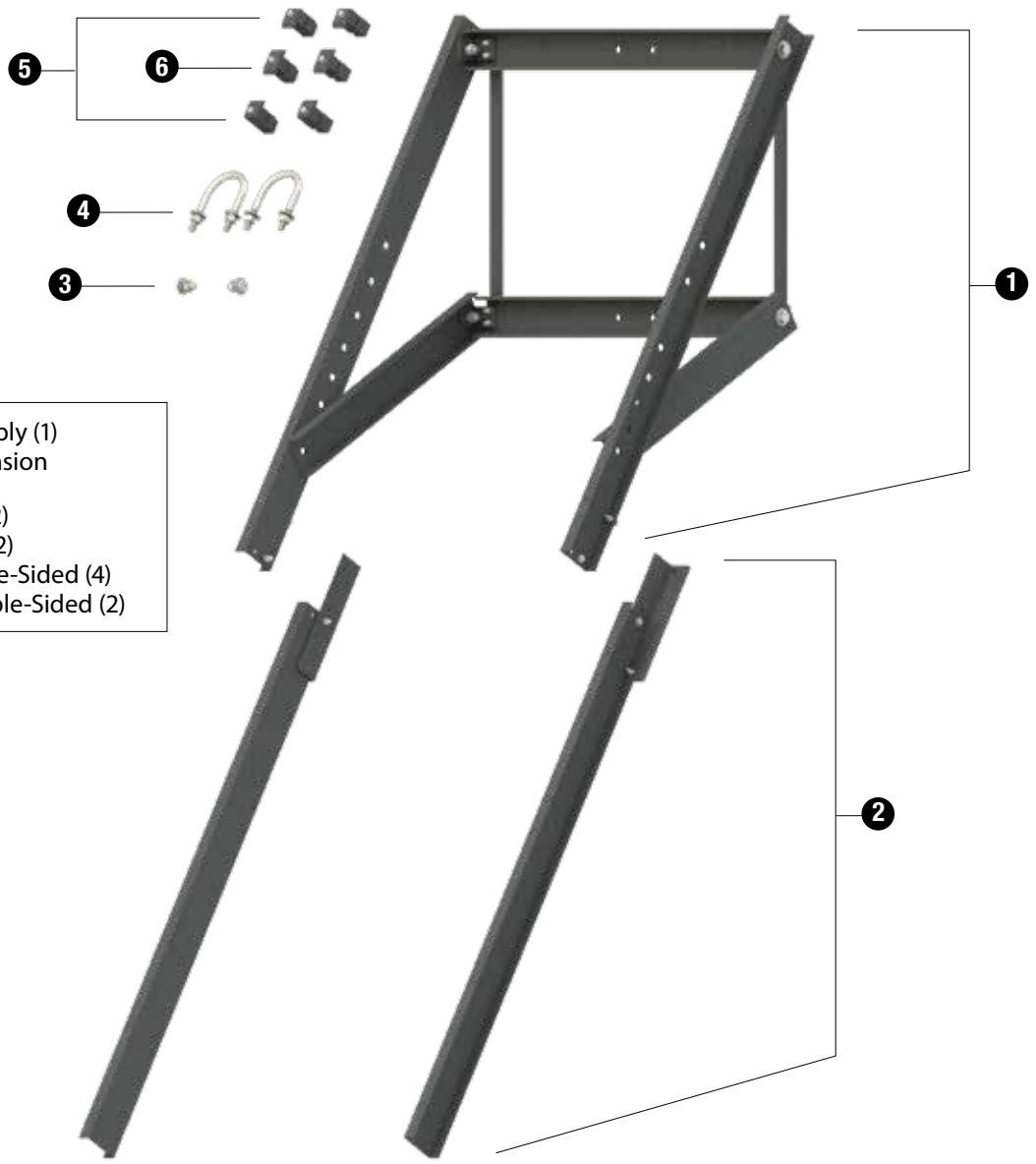

- 1. EasyMount Main Assembly (1)
- 2. Panel Support Rail Extension with Hardware (2)
- 3. Tilt Support Hardware (2)
- 4. U-Bolts with Hardware (2)
- 5. Solar Panel Clamp, Single-Sided (4)
- 6. Solar Panel Clamp, Double-Sided (2)

Grounding Hardware



Grounding Wire
12' Grounding Wire (1)



Grounding Lugs (2)



Ground Rod Clamps
1/2" Ground Rod Clamps (2)



Cable Ties (12)

2. System Installation

Tech Specs	Running Amps	Volts	Max CFM	Power Cord	Max Pond Size	Max Depth	# Diffusers
SS20-BB	2	24v	2.0	N/A	2 Acres*	20'	2

*Ponds greater than 2 Acres require multiple systems

A) Tools & Hardware Required

TOOLS

- Post Pounder
- Sledge Hammer
- Post hole digger or auger
- Wheelbarrow
- Shovel
- Rake
- Step Ladder
- 1/2" Drill (cordless or electric)
- 1/4" x 6" drill bit
- 5/8" x 6" drill bit
- 7/16" socket and ratchet
- 7/16" wrench
- 1/2" wrench
- 3/4" deep-well socket and ratchet
- 3/4" wrench
- 5/16" nut driver or wrench
- #2 Phillips screwdriver
- #2 slotted screwdriver
- Tape measure
- Marker or pencil
- 4' level
- Cable cutters
- C-clamps or bar clamps (2 with a minimum 4" throat depth)
- Boat or raft
- Coast Guard-approved life jacket
- Compass (or smart phone with compass app)
- Cardboard/blankets/towels to block solar panel energy during installation)
- 6-8 gallons of cold water (bucket or hose)

HARDWARE

- 2-1/2" dia. x 10' (min) Schedule 40 Galvanized Steel Pole (2.875" O.D. / 2.47" I.D.)
- 1/2" dia. x 8' copper grounding rod
- 1/2" dia. x 8" rebar (2) (recommended)
- Concrete bags - 60 lb (5) or 80 lb (4)
A rapid set product is recommended for 1-day installations.
- 2 x 4 wooden block (6" - 8" long)
- 2 x 4 x 8' wooden studs for bracing posts during concrete cure time (4)
- 24" wooden stakes (4)
- 3" wood screws w/ appropriate drill tip (Torx, Phillips, etc)
- Electrical or duct tape

See Video Instructions of the
Airmax SolarSeries Aeration
System Installation Online



B) Select a Location for the Airmax EasyMount System

- Ensure that holes for the solar mounting pole will not interfere with any underground utilities.
- Locate the system away from irrigation sprinklers.

***Attention:** For airline runs longer than 100', connector kits are required (sold separately). See Replacement Parts (Pages 19-20)

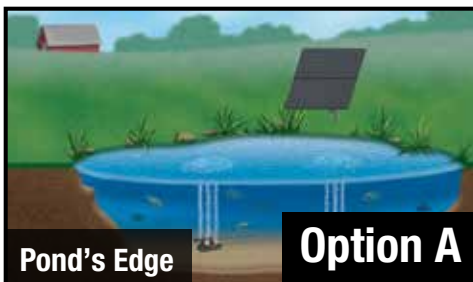

No Direct Burial Needed

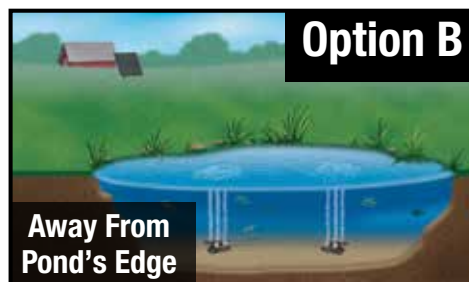

Direct Burial or Remote Manifold Needed

Option B with Remote Manifold

Use a single airline from cabinet to shoreline with valves at pond's edge.



Learn about installing an optional Remote Manifold Kit online at airmaxeco.com/RemoteManifold

2. System Installation - Continued

C) Post & Airline Installation

- 1) Select a solar panel mounting location well above the high-water mark of the pond/lake with optimum southern exposure. Be sure that mounting location is clear of anything that may obstruct exposure such as trees & shrubbery, buildings, privacy fences, etc. (Fig 1).
- 2) **Offset from Magnetic South:** Often referred to as magnetic declination, your east/west pivot is determined by the difference between magnetic south (compass) and solar south (true south/south pole). First, start by using the National Oceanic and Atmospheric Administration (NOAA) website below to determine your declination (Fig. 2).
<https://www.ngdc.noaa.gov/geomag/calculators/magcalc.shtml>
 Simply enter the site zip code in the **Location** field, click **Get & Add Lat/Lon**. Once the information auto-fills, click **Calculate** to find your declination. Be sure to note your latitude, as it will be used in a later step.
 For example, zip code 48005 (Armada, MI):
 Latitude = 42°, Declination = 7° 45' W.
- 3) Use a post-hole digger or auger to create a 10" - 12" diameter hole, 36" deep (min). This should leave you with approximately 84" above grade for your EasyMount Assembly.
Note: the hole can be bell-shaped at the bottom, but never at the top.
- 4) Use a 5/8" drill bit to drill a hole through the pole 8"-10" up from the bottom (it may be helpful to pre-drill a pilot hole with a smaller drill bit first). Insert 1/2" rebar into the hole so that an equal amount shows out eachside. Keep the rebar in place with electrical tape/duct tape or a cable tie to keep it centered until the post is set. This step is important to keep the post from rotating in the concrete under high wind conditions. We also advise against use of pre-cut cardboard tubes inside the holes for the same reason; the use of such tubes can lead to the entire cylinder of concrete rotating under windy conditions (Fig. 4).

- 5) Mix concrete and water in a wheelbarrow according to the manufacturer's specifications.
- 6) Place the pole in the center of the hole and pour concrete into the hole until it is 4"-6" inches below grade; keeping concrete slightly below grade will prevent curbing, which can lead to heaving during springtime frost in colder climates.
- 7) Plumb the pole with a level and brace using 2x4 studs, clamps and stakes (recommended). **Concrete cure times will vary depending on whether a traditional or rapid set product is used. Refer to manufacturer's instructions before installing the EasyMount assembly.**
- 8) Next, drive an 8' grounding rod into the ground 6"-8" away from the edge of the concrete. Use the proposed cabinet location to determine the placement of the grounding rod so that it is near the cabinet shut off switch (Fig. 8). Leave approximately 6" of the rod exposed above grade. This rod will be used later in the grounding section of the installation procedure.
Note: Grounding rods can be driven below grade after the rest of the system is installed and properly grounded. We also recommend placing the cabinet near the post mount assembly as shown below so that the solar panels provide shade for the cabinet.

- 9) Before installing your EasyMount Assembly, we recommend trenching and placing your airline. Begin by trenching from one side of the post hole to the pond's edge, approximately 8" deep. The trench can be 10"-12" to one side of the post hole so as not to disrupt the curing concrete.

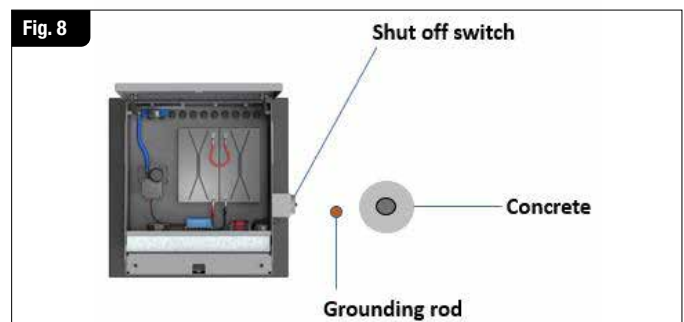
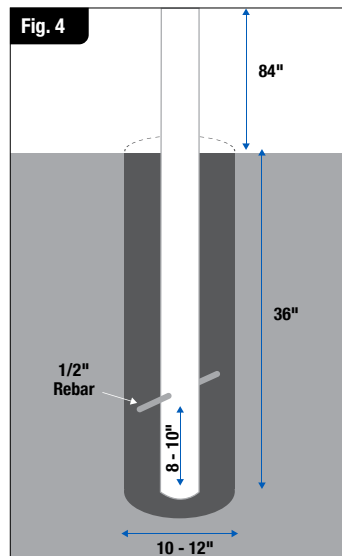
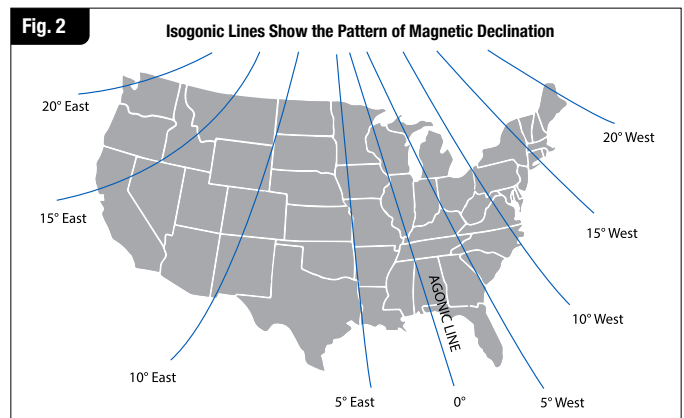
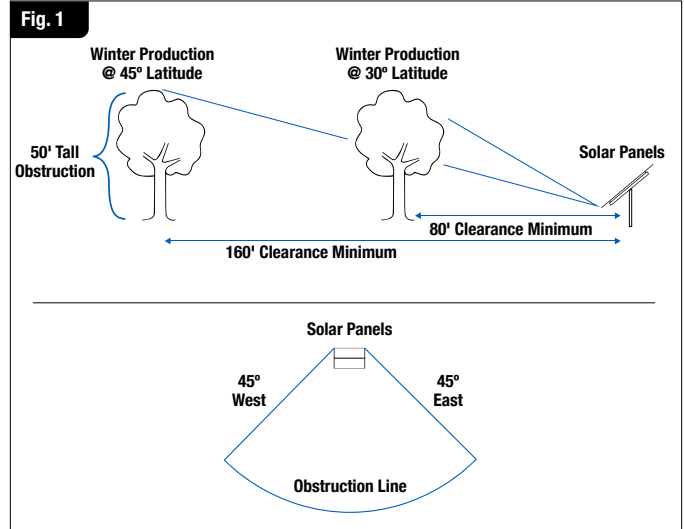

2. System Installation - Continued

- 10) Place airline in the trench from the pond's edge to the post making sure to leave 2'-3' extra for connections to the cabinet hoses once it is mounted in a later step (Fig. 10).

OPTION A: When distance between control panel and shore is less than 5') Use EasySet weighted airline. There must be a separate run of airline for each diffuser that will be installed. Leave remaining airline coiled at the pond's edge.

OPTION B: When distance between control panel and shore is more than 5') Use Direct Burial airline. There must be a separate run of airline for each diffuser that will be installed. Join multiple sections of direct burial airline using 5/8" connector kits. First, slide two hose clamps onto one section of airline. Next insert the 5/8" insert adapter halfway into one section of airline and then insert into the next section of airline. Using a flathead screwdriver or nut driver, secure one of the hose clamps onto each half of the insert adapter.

OPTION B with Remote Manifold:

Refer to the Remote Manifold Kit manual or watch the installation video at airmaxeco.com/RemoteManifold for more information.

- 11) Backfill the trench in a few places to keep airline in place.



D) EasyMount Main Assembly Installation

- Using a pencil or permanent marker, mark the post approximately 3" down from the top on the south side.
- If installing with one person, we recommend clamping a 2x4 block to the post at the 3" mark using a large clamp. This block will provide a shoulder/shelf for the upper beam of the EasyMount Main Assembly to rest on while installing the U-bolts in Step 3 (Fig. 2).
- First, rest the EasyMount Main Assembly upper beam on your clamp/block and secure in place using the two U-bolts, washers, lock washers and nuts. Tighten one half turn past hand tight using a 3/4" deep-well socket wrench. Secure the lower pole mount beam with the second U-bolt and tight one half turn past hand tight. Leave the U-bolts loose enough to pivot the assembly (Fig. 3).
- Next, pivot the EasyMount assembly in the desired direction to face solar south, based on the recommended angle for your region, and tighten all four U-bolts securely using a 3/4" deep well socket wrench.
- Use the latitude of your region to set the optimal tilt angle (Fig. 5A). Some smart phone compass apps will include your latitude and longitude on the screen, OR you can refer back to the NOAA website from the previous section to find your latitude.



a) If you will not be running your system in winter months, then simply use your latitude as your reference point and set your tilt angle to the angle closest to your latitude (i.e. 42° latitude = 40° tilt angle setting).

b) If you plan to run your system all year, use your latitude and add between 10°–15° when setting your tilt angle to get optimum performance when daylight hours are at their shortest. For example, 42° latitude could be set to the 55° or 60° setting on the EasyMount support rail; this will give you the optimum tilt angle in winter months when daytime hours are considerably shorter (Fig. 5B).

Note: Airmax recommends leaving your tilt angle set for optimum performance during the winter months when daylight hours are reduced by nearly 50%. The solar panels will receive ample sunlight in the other seasons to effectively power the system even when adjusted for winter operation.

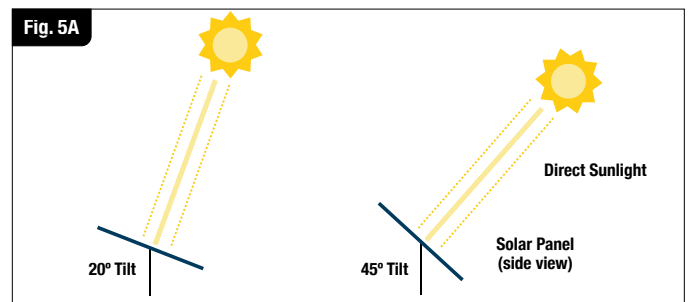
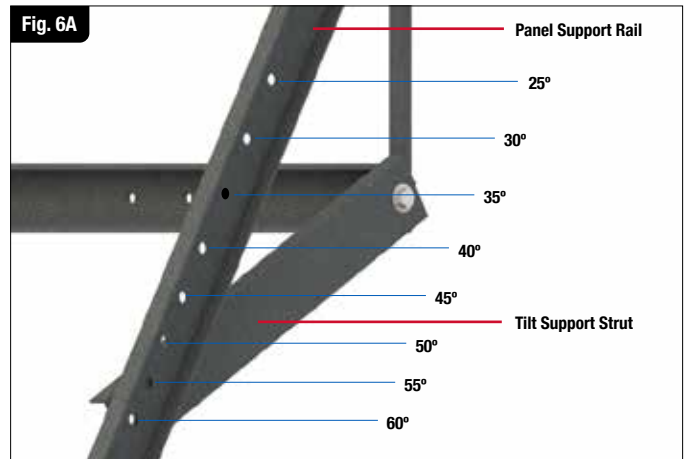

Fig. 5B RECOMMENDED TILT ANGLE	
Latitude	Tilt Angle Setting
0° to 19° (Vietnam – Thailand)	25° or 30°
20° to 25° (Hawaii – S. Florida)	35° or 40°
26° to 30° (S. Texas – N. Florida)	40° or 45°
31° to 35° (Mid-Texas – N. Georgia)	45° or 50°
36° to 40° (S. Nevada – New Jersey)	50° or 55°
41° to 45° (S. Idaho – Northern Michigan)	55° or 60°
46° to 50° (S. Washington – S. Canada)	60°
51° to 65° (S. Canada - Northern Alaska)	60°

2. System Installation - Continued

- 6) Next, remove the tilt support hardware from the temporary location on the support rail. Align the hole on the tilt support strut with the desired hole on the support rail (**Fig. 6A**). The recommended angles shown in the table (**Fig. 5B**) are based off the difference from the horizontal plane. Tighten completely using two 3/4" wrenches (**Fig. 6B**). Repeat for the opposite side.



- 7) Continue by installing a panel support rail extension. First, remove the bolts, lock washers and nuts from the end of the rail extension connector to attach to the panel support rail. Tighten using one 7/16" wrench and one 7/16" socket wrench (**Fig. 7**). Repeat for the opposite side.



- 8) Lastly, tighten the four pivot bracket bolts using a 3/4" socket wrench (**Fig. 8**).



2. System Installation - Continued

E) Solar Panel Installation & Grounding

CAUTION: To prevent possible injury, cover solar panels with either cardboard, blankets, or towels to prevent any voltage transmission through solar panel cables during installation.

Avoid installing solar panels on windy days to prevent possible accidental damage to equipment.

1) First, position a single-sided solar panel clamp at the bottom edge of one panel support rail extension and tighten using a 7/16" wrench. Do not tighten the top hex bolt as you will need room to slip the bottom edge of the solar panel frame into the clamp (**Fig. 1**). Repeat for the second panel support rail extension.



2) Temporarily position one double-sided solar panel clamp at the joint between the panel support rail and the rail extension; hand tighten only at this time (**Fig. 2**). Place the second double-sided clamp in the same position on the opposite support rail.



3) Next, position a single-sided solar panel clamp at the top edge of one panel support rail and hand tighten only (**Fig. 3**). Repeat for the last single-sided clamp.



4) Position the first solar panel so that it rests on the lower single-sided clamps. It does not matter which side the wiring junction box faces, as long as the second solar panel is positioned in the same manner once installed in Step 6. See orientation in (**Fig. 4**). After ensuring the solar panel frame is seated beneath both clamps, hand tighten each clamp.

Note: We recommend using two people when handling and installing solar panels.



2. System Installation - Continued

5) Next, loosen the double-sided clamp from the rail on each side. Then position the clamps so that they seat against the top frame of the solar panel. Secure clamps to the rail but leave the top hex bolt loose to allow for positioning of the next solar panel (Fig. 5).

Fig. 5



6) Position the second solar panel atop the double-sided clamps, making sure that the wiring junction box faces the same direction as the lower panel and hand tighten. Then slide the top two single-sided clamps down until they seat against the top frame of the upper solar panel. Secure the clamp to the rail with a 7/16" wrench, but leave the top hex bolts only hand tight (Fig. 6).

Fig. 6



7) Use your tape measure to center both the upper and lower solar panels widthwise on the panel support rails. Once the panels are properly centered, secure all clamps using a 7/16" wrench but do not over tighten. Ensure that you have tightened all bolts securing the clamps to the rail as well as the upper bolts securing the solar panels in place (Fig. 7).

Fig. 7



GROUNDING YOUR SYSTEM

8) First, attach a grounding lug to the center grounding location of each solar panel using the screw and nut provided (Fig. 8). Tighten each using a Phillips screwdriver.

Fig. 8



2. System Installation - Continued

- 9) Feed one end of the 12' copper grounding wire through each of the solar panel grounding lugs and secure using a slotted screwdriver (**Fig. 9**).



- 10) Next, slide one ground rod clamp onto the opposite end of the 12' copper grounding wire. Loosen the bolt on the ground Rod clamp and attach it to one of the upper U-bolts on the EasyMount assembly and secure in place, making sure the grounding wire is making good contact with the U-bolt (**Fig. 10**). Be sure to leave some slack in the cable in case the solar panel tilt angle should ever be changed.



- 11) Feed the remainder of the grounding cable down the pole and attach in 3–4 places using the cable ties provided (**Fig. 11**).



- 12) Last, feed the grounding cable through a ground rod clamp and temporarily secure in place on top of the grounding rod. Excess cable can be cut and discarded or buried (**Fig. 12**).

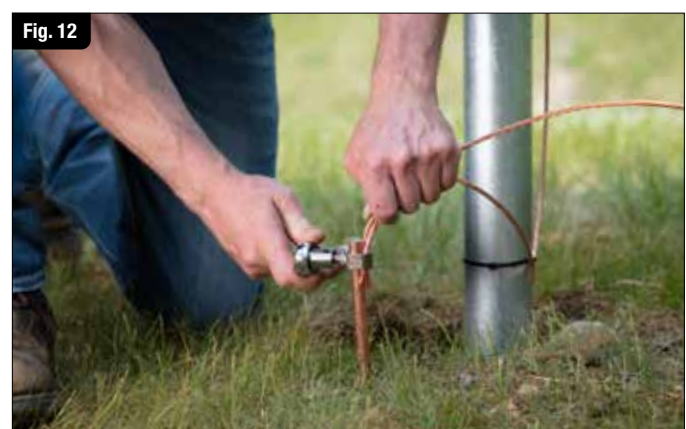

2. System Installation - Continued

F) Cabinet Installation & Wiring

OPTIONAL FINAL GRADE AND SURFACE PREP: To prevent possible damage to equipment during lawn maintenance AND to prevent shading from vegetation growth, the immediate areas beneath and around your Airmax SolarSeries assembly can be prepared with ground fabric and finished with stone or mulch.

- 1) Place the cabinet on the ground near the solar mounting setup with the backside of the cabinet toward the solar panels (Fig. 1).

Note: The side of the cabinet with the external shut-off switch should be positioned so that it is within 48" of the grounding rod.

- 2) Make sure the external shut-off switch is in the OFF position.
- 3) Connect the positive wire from the first solar panel to the corresponding cable from the cabinet switch (Fig. 3).

- 4) Connect the negative lead from the first solar panel to the positive lead from the second solar panel (Fig. 4).

- 5) Connect the negative lead from the second solar panel to the corresponding cable from the cabinet switch (Fig. 5).
- 6) Connect the ground wire coming from shut-off switch to the grounding clamp at the ground stake.
- 7) The grounding rod can now be driven down until flush with the ground.



2. System Installation - Continued

G) Connect Airlines

- 1) With the cabinet in place, feed hoses from beneath the cabinet to the hoses coming from the trench.
- 2) Connect Airlines to the Manifold Hoses

Option A & B: Insert one side of a 3/8" to 5/8" coupler into the 5/8" weighted or direct burial airline and secure with a hose clamp. Then insert the other side of the coupler into the manifold hose and secure with a hose clamp. Repeat for the remaining manifold hose (**Fig. 2**).

Option B with Remote Manifold:

Refer to the Remote Manifold Kit manual or watch the installation video at airmaxeco.com/RemoteManifold for more information.



H) Install ProAir Diffusers

- 1) Unroll the EasySet weighted airline and remove any twists. Join enough sections of weighted airline, using 5/8" connector kits, so that the airline can rest on the bottom of the pond, from the pond's edge out to the planned location for each diffuser. For Option B installations, connect the weighted airline to the direct burial airline or Remote Manifold Kit at the pond's edge (**Fig. 1**).

Note: Diffusers should be placed equally apart or in areas of low water movement for optimum performance. If you need help choosing the correct location for your diffusers, please contact Airmax or your local dealer.



- 2) Assemble and Connect ProAir Diffusers

See the ProAir Diffuser manual for assembling and connecting the diffusers (**Fig. 2**).



- 3) Start the Aeration System

Begin by connecting the red MPPT wire to the orange Wago connector (**Fig. 3**). Start by flipping up the orange tab that has the empty terminal, then insert the red wire and lock the tab, making sure the wire is secure.



2. System Installation - Continued

- 4) Turn the external shut-off switch to the ON position. Turn the internal switch to the ON position. Open the ball valve for the first diffuser and close the second ball valve. Provided there is sufficient sunlight to begin powering the compressor, airflow will be sent to the first diffuser (Fig. 4).

Note: It is helpful to have the diffuser emitting air while setting it in the water body in the next step so that proper placement can be determined through a visible bubble pattern.



- 5) Install the ProAir Diffusers

Option A:

Installing Diffusers From a Boat/Raft (Fig. 5A): Have one person on shore guiding the airline as a second person, using a boat or raft, extends the airline out to the area of the pond where the diffuser will be located. Gently lower the diffuser to the pond bottom using the weighted airline to ensure that the ProAir 2 diffuser remains in the upright position. You may also choose to thread nylon rope through the diffuser manifold and use the nylon rope to gently lower the diffuser until it reaches the pond floor. Release one side of the nylon rope and remove. Repeat until all diffusers are in position.

Option B:

Installing Diffusers From Shore (Fig. 5B): For smaller ponds you may choose to install the diffusers from shore. Have one person guide the airline while another walks around the pond with the diffuser. Then thread nylon rope through the diffuser manifold handle. Use the nylon rope and airline to gently guide the diffuser into place. Once set, release one side of the nylon rope and pull to shore. Repeat until all diffusers are in position.

- 6) REPEAT Steps FOUR and FIVE for the second diffuser.



I) Finalize System Install

- 1) Bubbles should be noticeable on the pond's surface from the diffuser locations. Adjust the airflow valves on the compressor manifold (**Fig. 1**) (For Option B with Remote Manifold, do this step at the remote manifold). Once an adjustment is made, you may need to wait several minutes to see the results at the diffuser location(s).

Note: Airlines should only need to be partially closed or adjusted if one diffuser needs more air due to a greater depth. If both diffusers receive optimum airflow with both valves wide open, do not adjust or restrict airflow.

Restricting airflow unnecessarily will increase the compressor running temperature.



2. System Installation - Continued

2) Secure Cabinet Lid

Close the cabinet lid and use one of the keys provided to secure **(Fig. 2)**. Locking the cabinet lid will eliminate unwanted vibration. Inspect all airline connections in the trench and at the manifold hoses to ensure all hose clamps are secure and free of leaks. Backfill the remainder of the trench from cabinet to shore.

Fig. 2



3) Set up MPPT SmartTechnology App on your Smart Phone **(Fig. 3)**.

- a) Open the App Store on your phone or tablet. Then search victronconnect and download/install the Victron Connect – Business app.
- b) Once the app has been installed on your device, OPEN the app and allow your phone or tablet to find devices. Note: You will need to make sure that your Bluetooth is turned on and must be within range of the aeration cabinet to properly connect.
- c) You will be prompted to Pair Device and will be provided a default PIN, 000000 (six zeros). Enter the PIN and select Pair.
- d) Use this app any time you are in range of the system to view charging status, voltage, amperage or run-time/off-time monitor.

Fig. 3



3. Initial Start-Up & Seasonal Operation

WHENEVER TURNING THE SYSTEM ON OR OFF, REFER TO THE STEPS BELOW TO ENSURE POWERING UP AND SHUTTING DOWN FOLLOW THE CORRECT ORDER TO AVOID DAMAGE TO SYSTEM COMPONENTS.

- **POWERING UP**

Turn the **EXTERNAL** switch to the **ON** position

Turn the **INTERNAL** switch to the **ON** position

- **SHUTTING DOWN**

Turn the **INTERNAL** switch to the **OFF** position

Turn the **EXTERNAL** switch to the **OFF** position.

 The circulation of poor quality, low oxygen, deep water to the pond's surface can introduce harmful gases and by-products into the previously healthy upper regions of the water column. These by-products can make the upper regions unfit for aquatic life and could result in fish kill.

Initial Start-Up Procedure To Prevent Fish Kill:

Follow this procedure anytime the system has been shut off for an extended period of time.

Day 1: Run system for 30 minutes; turn system off for remainder of day.

Day 2: Run system for 1 hour; turn system off for remainder of day.

Day 3: Run system for 2 hours; turn system off for remainder of day.

Day 4: Run system for 4 hours; turn system off for remainder of day.

Day 5: Run system for 8 hours; turn system off for remainder of day.

Day 6: Run system for 16 hours; turn system off for remainder of day.

Day 7: Begin running system 24 hours/day, 7 days/week.

If operating during the winter season, condensation could cause airlines to freeze. If airlines freeze, follow this procedure:

- 1) Determine which ball valve controls the airline containing the blockage and leave that valve in the open position while closing the other.
- 2) Turn off power at the internal switch as well as the external switch, then loosen the hose clamp at the flex tube that attaches to the underground airline. Disconnect the blue flex tube from the underground airline.
- 3) Pour approximately 1 cup of isopropyl alcohol into the airline.
- 4) Re-attach the flex tube to the underground airline and turn the external switch to the ON position, then turn the internal switch to the ON position.. Allow the compressor to run until the airline is free of ice.

Note: You may have to repeat the process if some airlines do not thaw the condensation on the first attempt

SUMMER OPERATION

To reduce the risk of fish kills in hot summer months and for optimum aeration benefits, Airmax SolarSeries Aeration Systems should run for as many hours as possible throughout the summer

WINTER OPERATION

Owner assumes all responsibility for operating Airmax Aeration Systems during winter months. Operating in freezing conditions on an ice-covered pond will cause large open water areas at diffuser sites. Ice thickness around open areas will be much thinner than the surrounding areas. Airmax strongly recommends that "Danger - Thin Ice" be posted at frequent intervals around pond. In colder climates where heavy snowfall is likely, we recommend wrapping the cabinet in burlap to prevent blowing snow from entering through the back and side louvers.

IF YOU CHOOSE TO TURN YOUR SYSTEM OFF FOR THE WINTER, SIMPLY TURN THE INTERNAL SWITCH TO THE OFF POSITION, BUT LEAVE THE EXTERNAL SWITCH ON TO ALLOW SOLAR PANELS TO KEEP THE BATTERIES CHARGED OVER WINTER.

4. Maintenance

Airmax Aeration Systems are designed for low-maintenance and require minimal scheduled maintenance. Cabinet inlets and outlets should be kept free of debris and weed growth allowing normal ventilation.

- Always turn off system before performing any maintenance or troubleshooting.
- Always turn off system and refer servicing to a qualified electrician when cord is damaged or frayed or when compressor, compressor fan, or other electrical components are producing unusual noises or odors.
- Always use parts that are supplied or approved by Airmax, Inc. Use of other parts may result in poor performance and could create a hazardous situation.

Note: Local environmental conditions may require more frequent maintenance.

WARNING: Compressors are equipped with a thermal overload switch. If temperature becomes high enough to trip the overload, the compressor will shut down.

EVERY 3-6 MONTHS

Air Filter: Clean cabinet filter & replace compressor air filter.

Cooling Fan: Check to ensure that the cooling fan is operating. Cool air should be pulled in through the filter media and blown over the compressor.

Pressure Gauge: Mark pressure gauge PSI upon initial start-up. Check to verify pressure has not significantly risen above or dropped below the initial reading. Typical operation will range between 4–8 PSI depending on depth.

Pressure Relief Valve: Check to ensure air is not escaping from the valve and replace valve if needed.

EVERY 24-36 MONTHS

Membrane Sticks: We recommend inspecting and/or cleaning the membrane diffuser sticks every 24-36 months, especially anytime the pressure gauge reading is significantly higher than normal or if there is a reduction of bubbles from the diffuser. To clean, use Airmax D-Scale™ (#530298) and a soft cloth.

EVERY 4 YEARS

Maintenance Kit: We recommend installing a compressor maintenance kit every 4 years to maintain proper compression and airflow from the compressor.

5. Troubleshooting

IF COMPRESSOR IS NOT OPERATING:

ISSUE	CHECK	LIKELY CAUSE	CORRECTION
Power OFF	Check external shut off switch	Switch is in the OFF position	Turn switch to the ON position
Batteries Charging	Check MPPT app on phone for system status	Battery voltage is too low	Allow time for system to charge
No Power to Compressor or Batteries	Check connections on MC4 Connectors	Connectors not making proper contact	Properly secure connector/wiring harness
Solar Panels Obstructed/Batteries Not Charging	Check solar panel surface	Debris on solar panel	Clear solar panel of snow, leaves, or other obstructions
	Check the area in front of panel surface	Vegetation blocking exposure	Cut or remove vegetation

IF COMPRESSOR IS OPERATING:

ISSUE	CHECK	LIKELY CAUSE	CORRECTION
No bubbles to any diffuser plates.	Check for leaks in airline	Loose clamp/connection	Tighten hose clamp
	Check position of ball valves	Ball valves restricting airflow	Open ball valves to allow more airflow
	Check for airflow at end of blue flex tubes	Water in weighted airline	Purge airlines individually by closing one ball valve completely to purge airline. Repeat for second diffuser.
No bubbles to some diffuser plates.	Check position of ball valves	Ball valve restricting airflow	Open ball valve to allow more airflow
	Pull and inspect diffuser for debris	Debris or pond weeds interrupting airflow	Clean or replace diffuser sticks

NOTE: When inspecting or replacing any of the in-line fuses on the Airmax SolarSeries Battery Backup Aeration System, please follow the steps below:

- 1) Turn off the internal load switch.
- 2) Turn off the external switch.
- 3) Remove the battery wire from the Wago connector at the battery jumper.
- 4) Inspect or replace the desired fuse(s).
- 5) Reconnect the battery wire to the Wago connector.
- 6) Turn on the external switch
- 7) Turn on the internal load switch.

If a fuse fails immediately after replacement, contact Airmax customer service at 866-424-7629.

6. Replacement Parts / Accessories

SolarSeries Battery Backup Replacement Parts

1. #510656 – Air Intake Pre-Filter, Metal Cabinet
2. #654123 – Cooling Fan, 24v DC
3. #601200 – Airmax SilentAir Compressor, 24v DC
4. Air Filter
 - #510150 – Air Filter, Complete
 - #510151 – Air Filter Media Only
5. #654125 – 2 Port Manifold Assembly, Enclosure Mount
6. #490272 – Pressure Gauge
7. #654130 – Pressure Relief Valve, 15 PSI
8. #490191 – 3/8" Flex Tube Assembly (Blue)
9. #654830 – Battery, 12v AGM (set of 2 ONLY)
10. #654134 – DC Shut Off Switch
11. #654133 – MPPT Controller
12. #490333 – Diffuser Sled
13. #490340 – Check Valve
14. #510168 – PTFE 6" Membrane Stick
15. #510119 – 5/8" Weighted Airline, 100' Roll
16. #510120 – 5/8" Direct Burial Airline, 100' Roll
17. #600194 – Airmax 4-Port Remote Manifold Kit
18. #490205 – 3/8" to 5/8" Connector Kit
19. #490206 – 5/8" Connector Kit

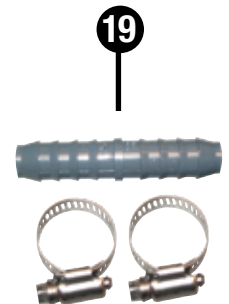
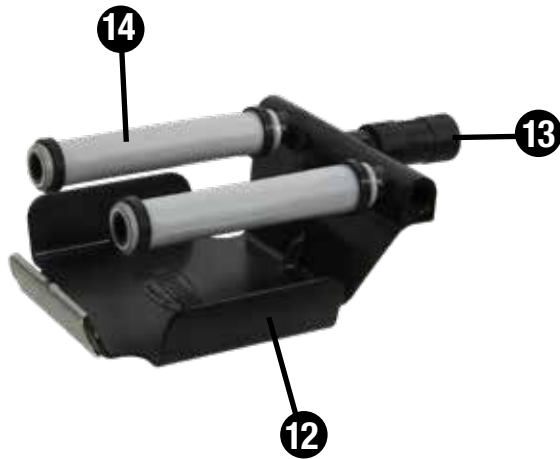
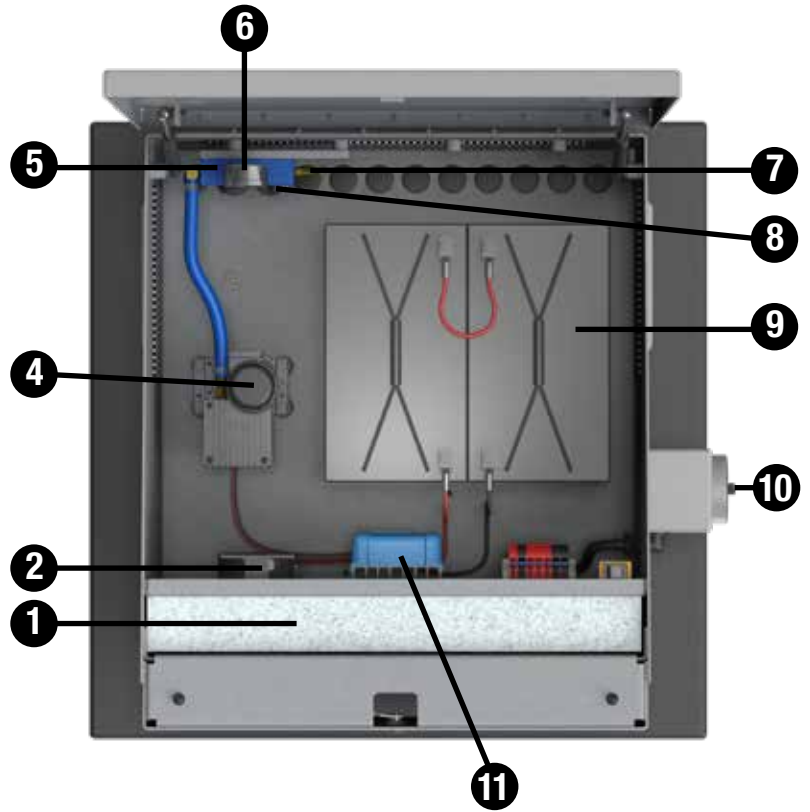

SolarSeries EasyMount Assembly Replacement Parts

1. #653911 – Solar Panel
2. #654117 – EasyMount Assembly Complete
3. #654116 – EasyMount Post-Mount Assembly
4. #654119 – EasyMount Rail Extension
5. #654126 – EasyMount Support Rail & Support Strut
6. #654127 – EasyMount Single-Sided Clamp
7. #654128 – EasyMount Double-Sided Clamp

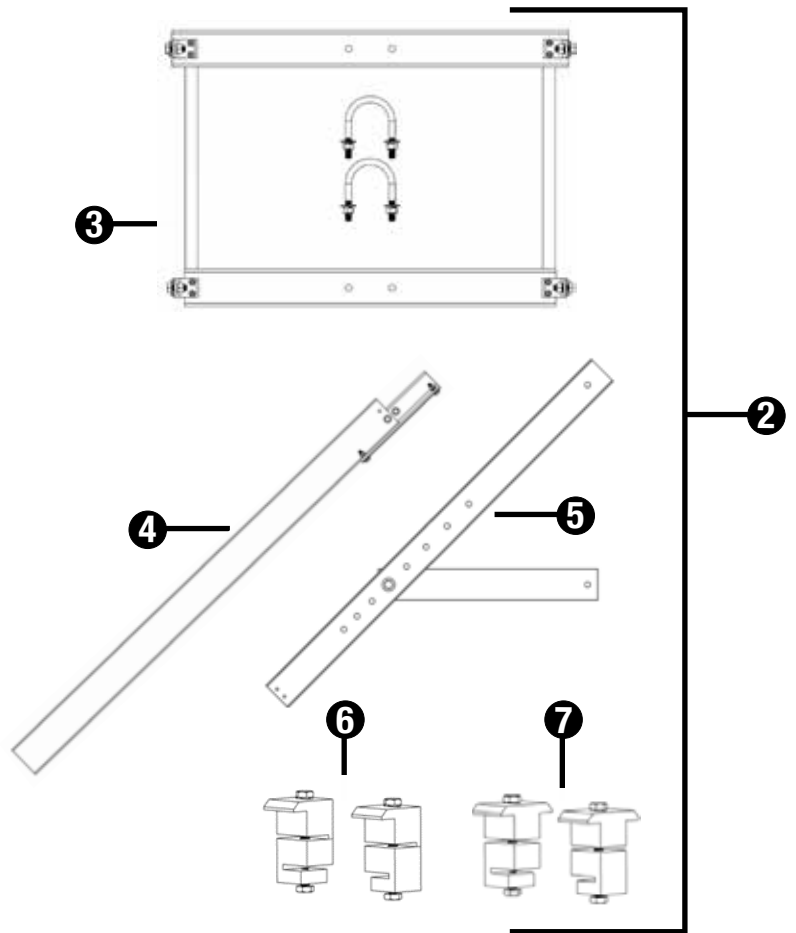
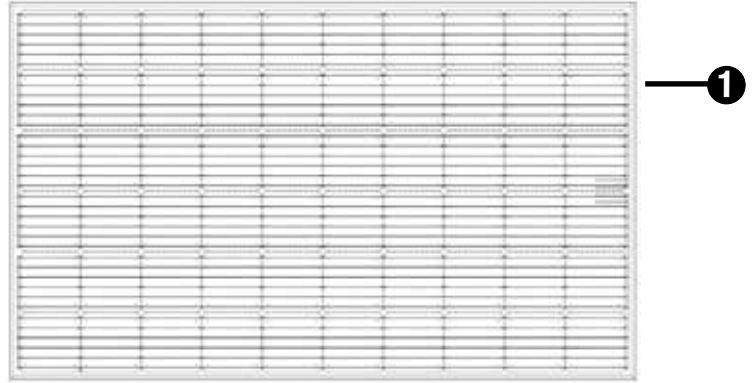

Airmax, Inc.

Airmax Aeration Systems

United States Limited Warranty

Airmax, Inc. warrants to the original purchaser (the end user) of any Airmax SolarSeries Aeration System manufactured by Airmax, Inc. that any component which proves to be defective in materials or workmanship, as determined by the factory within 1 year (battery) / 3 years (compressor, electrical components & mounting hardware) / 5 years (diffusers, airline) / 10 years (cabinet) / 25 years* (solar panels) from the original purchased date, will be repaired or replaced at no charge with a new or remanufactured part, and returned freight prepaid. The end user shall assume all the responsibility and expense for removal, packaging, and freight to ship to Airmax, Inc. to determine the warranty claim and for all reinstallation expenses.

The warranty is void in cases where damage results from: improper installation, improper wiring, alteration, lightning, careless handling, misuse, abuse, disassembly of motor or failure to follow maintenance or operating instructions. Modification or repair by an unauthorized repair facility will void the warranty.

In no case will Airmax, Inc. or its dealers accept responsibility for any costs incurred by the user during installation, removal, inspection, evaluation, repair, parts replacement, or for return freight. Nor will any liability be accepted for loss of use, loss of profits, loss of goodwill, for consequential damage, or for personal injuries to the purchaser or any person.

In the event of problems believed to be covered under warranty, it will be necessary to notify the dealer who will try to help resolve the problem and who may contact the factory for additional assistance. If it is concluded that there may be a defect which may be covered under warranty, it will be necessary to get a Return Material Authorization (RMA) from the dealer before shipment. Freight collect shipments will not be accepted by the factory on warranties or repairs.

The product or part(s) must be returned freight prepaid, to the factory, as directed, and in its original packaging or in a container which will prevent damage. Parts returned under warranty and damaged during shipping will not be covered under warranty for the shipping damage. If the factory evaluation of the returned goods concludes that the failure is due to defects in materials or workmanship, the part or parts in question will be replaced under warranty with new parts, remanufactured parts, or will be repaired at the factory's option. The warranty period for all parts supplied under warranty will terminate at the end of the original product's warranty. All warranty shipments from the factory will be shipped freight prepaid.

Warranty registration is HIGHLY recommended.

No implied warranties of any kind are made by Airmax, Inc. for its products, and no other warranties, whether expressed or implied, including implied warranties of merchantability and fitness for a particular purpose, shall apply. Should an Airmax, Inc. product prove to be defective in materials or workmanship, the retail purchaser's sole remedy shall be repair or replacement of the product as expressly provided above.

The manufacturer's warranty will begin from the dealer's original purchase date if the product is not registered. To register a product, you are required to fill out the warranty registration form at airmaxeco.com/warranty. Warranty registration must be submitted directly to Airmax within 30 days of the end-user's purchase date.

***Degradation of solar panels not to exceed 2% in year one and 0.58% annually from years 2 to 30.**



Airmax, Inc.

15425 Chets Way Street
Armada, MI 48005

(866) 4-AIRMAX
airmaxeco.com