



Trumpet



Gusher



Crown and Trumpet

AIRMAX[®]

LakeSeries[®]
Floating Fountain
Three Phase Owner's Manual

7.5 HP Fountain • 460v/12A/60Hz • 654145

10 HP Fountain • 460v/16A/60Hz • 654176

OWNER'S MANUAL FOR:

LakeSeries 7.5 HP & 10 HP 460v Three Phase Floating Fountain



Gusher

THANK YOU FOR CHOOSING The Airmax® LakeSeries Floating Fountain



See in Action | LakeSeries Spray Patterns
airmaxeco.com/product/airmax-lakeseries-fountains/

TABLE OF CONTENTS

SECTION	PAGE
1 System Components	3
2 Safety	3
3 System Installation	4-5
4 Maintenance & Winter Storage	5
5 Troubleshooting - Fountain	5
6 Replacement Parts	6-7
7 Warranty	8

LakeSeries Floating Fountain

Owner's Manual - 460v Three Phase

Airmax LakeSeries Floating Fountain

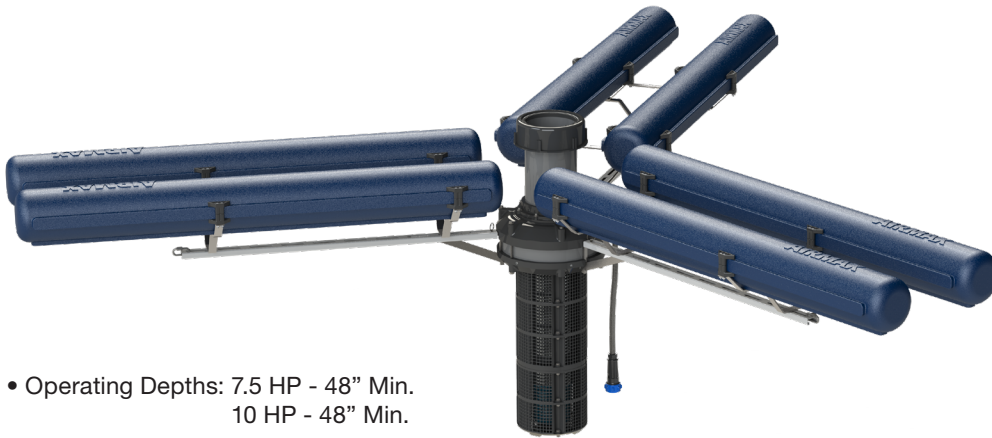

- Operating Depths: 7.5 HP - 48" Min.
10 HP - 48" Min.
- Multiple Spray Patterns (sold separately)
- 5 Year Warranty



Crown & Gusher

2. Important Safety Instructions

- Under NO circumstances should anyone enter the water with the electrical equipment plugged in and/or in operation. This fountain has NOT been evaluated for use in swimming areas.
- Warning - Risk of electric shock. To reduce the risk of electric shock, be certain that the fountain control panel is connected only to a properly grounded power source. Installing an acceptable safety shut off switch between the main power source and control panel is recommended.
- To reduce the risk of electrical shock, install only on a circuit protected by a Ground Fault Circuit Interrupter (GFCI).
- ALWAYS use a qualified electrician to install a power source.
- ALWAYS use with the appropriate Airmax Control Panel.
- NEVER run the unit out of the water. It will damage the seals and create a dangerous situation for the operator.
- NEVER lift or drag the fountain by the power cord.
- During freezing temperatures, remove fountain and store inside.
- If installing the fountain from a boat or raft ALWAYS wear a Coast Guard approved personal flotation device.

1. System Components



Power Cord
w/strain relief cable attachment



**Airmax 460v/25A
Three Phase
Control Panel**

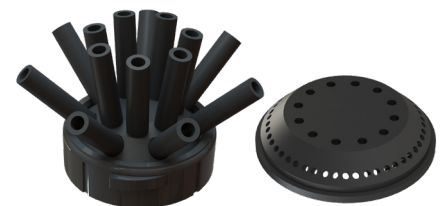

Spray Patterns
sold separately

Fig. 1

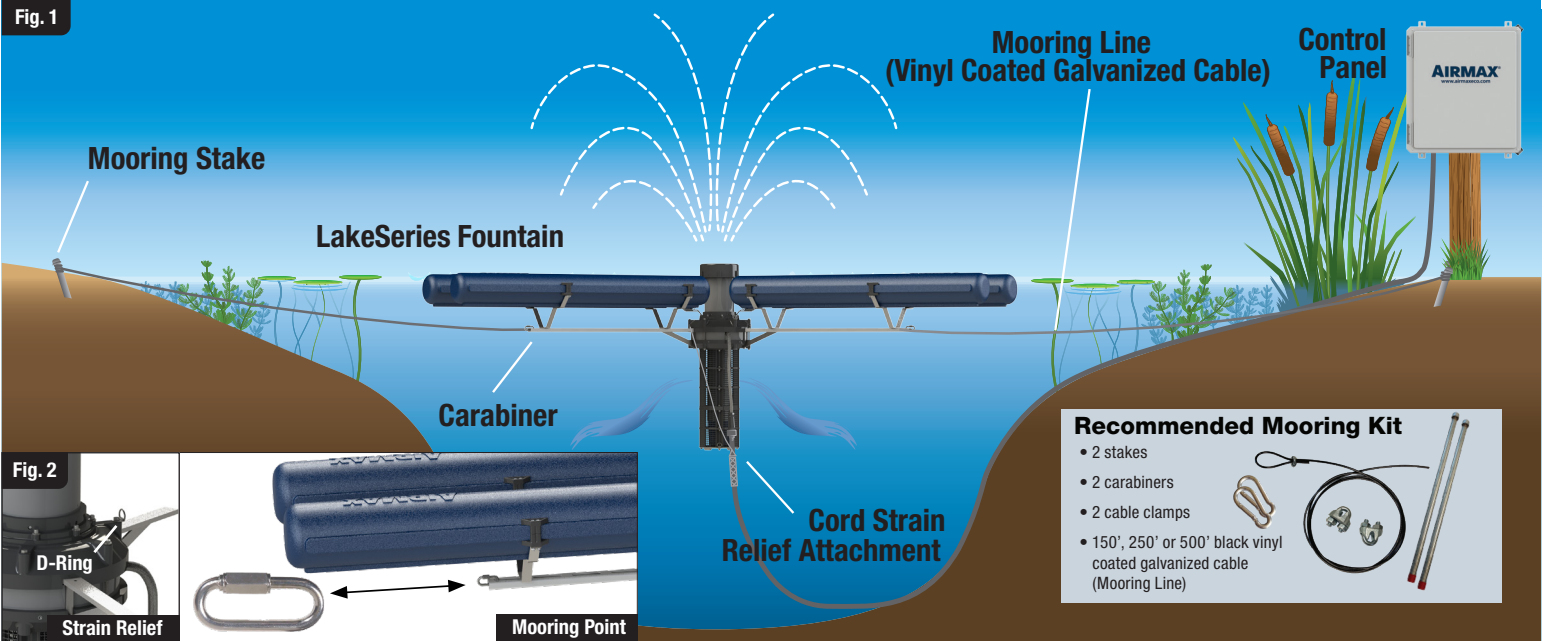

Fig. 2



A. System Components:

- Fountain Pump with Quick Disconnect, Float Mount Brackets (installed)
- Fountain Float
- Power Cord
- Control Panel
- Spray Patterns (sold separately)

Mooring Kit Options:

- #651052 – 150' Mooring Kit
- #651054 – 250' Mooring Kit
- #651055 – 500' Mooring Kit

* Mooring Kit Not Included with Fountain

B. Fountain Installation:

- 1) We recommend to ALWAYS use a licensed electrician to provide proper pondside power for your Airmax Control Panel. This will ensure that if sufficient 460v Three Phase power is not available, a buck/boost transformer and main shut-off can be installed before the fountain control panel.
- 2) Mount the Control Panel in a fixed position. (For control panel installation and wiring instructions for your fountain and light set, please see control panel manual for details.)
 - a) If you are unable to perform installation of your control panel or light set, please contact your Certified Airmax Service Technician, and they can perform this installation for you.

3) Choose Your Spray Pattern (Fig. 3)

- a) The LakeSeries fountain offers multiple spray pattern options (sold separately).
- b) To change a pattern, simply unscrew the nozzle nut, replace the pattern and reinstall the nozzle nut (hand tighten only). Some spray patterns include a flow straightener which must be installed before the nozzle and nozzle nut.

Note: Airmax recommends installing the nozzle after the fountain has been moored in place and after turning the fountain on momentarily to clear out any debris that may have collected on the intake during installation.

4) Install Your RGBW LED Light Set (sold separately)

- a) First, install each light from a 4-light assembly by clipping the mounting bracket over one of the inner float rails and tightening the thumb screw. Space the lights evenly along the rail and ensure that the quick disconnect end of the 4-light assembly points toward the power unit. Light positions can be adjusted and directed individually for maximum pattern coverage.
- b) Repeat for each of the remaining light set assemblies.
- c) Install the LakeSeries Light Set Junction Box by removing one of the 1/4-20 bolts on the upper pump housing and placing the mounting bracket over the mounting hole. Reinstall the 1/4-20 bolt and tighten securely. Refer to the Airmax Light Set Manual for additional instructions.

Note: Do not remove the quick disconnect winterization caps until instructed under STEP 5 Assembling the Unit.

Fig. 3



Fig. 4

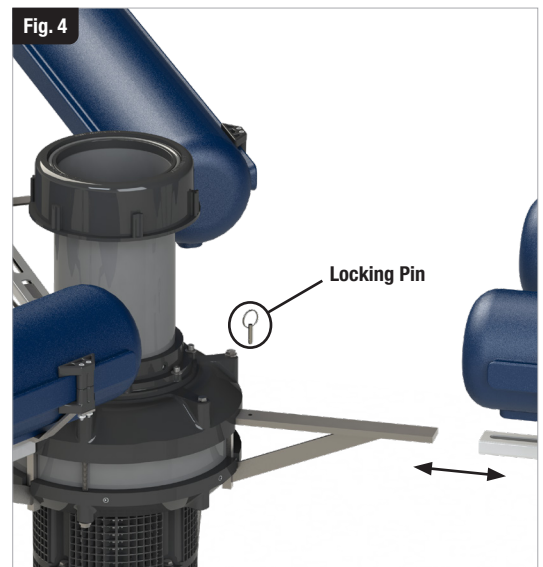

5) Assembling the Unit

- a) Lay the fountain power unit on its side near the pond's edge and connect the power cord using the quick disconnect. Then attach the power cord strain relief to one of the upper D-rings on the upper pump housing. (Fig. 2)
- b) Next, lay the fountain in the pond with the discharge facing the shore and install all but one of the float assemblies and secure in place with the locking pins tethered to the float mount brackets. (Fig. 4)
- c) Stand the fountain upright and install the last float assembly.
- d) Attach each mooring cable to the cable connecting links at the ends of each float support assembly. 2-point mooring should be sufficient for shore-to-shore mooring, but 3-point mooring can be used if desired. (Fig. 1)
- e) If installing with Airmax RGBW LED LakeSeries Light Sets. (Skip to STEP F if not installing with lights)
 - i) Connect each of the disconnects from the 4-light assemblies to each of the corresponding leads on the junction box and connect the light power cord to the quick disconnect on the bottom of the junction box. Be sure to avoid getting water in the disconnects during assembly.
 - ii) Save winterization caps for use when fountain is removed for the season or during maintenance.
 - iii) Attach the light power cord strain relief to one of the upper D-rings on the upper pump housing. (Fig. 2)
- f) Keeping the ends of the mooring cables on the shore, raise the end of the near float assembly until the weight of the fountain is supported by the float assemblies pointing toward the pond and walk the fountain into the pond until the intake basket no longer rests on the pond bottom.
- g) Attach the near mooring cable to an approved mooring stake at the pond's edge. Ensure the stake is driven securely into the ground. (Airmax Mooring Kits sold separately)
- h) Boat or walk the second mooring cable around to the opposite side of the pond and secure the fountain in place using a second mooring stake.
- i) Ensure mooring lines are snug to prevent the fountain assemblies from twisting and shifting during operation.
- j) To anchor the fountain using blocks or weights, spread the blocks far apart so the mooring lines are snug and the fountain cannot spin from the force of the motor, which could cause the lines to become tangled.

NOTE: When using anchors, we recommend 3-point mooring, using each connecting link on the float support assemblies.

4. Maintenance & Winter Storage

A. Maintenance

- 1) Disconnect ALL power from the fountain and lights before attempting any maintenance.
- 2) Periodically clean fountain intake screen of debris, algae and/or aquatic weeds.
- 3) Periodically clean light set lenses with a non-abrasive brush and cleaner.
- 4) Sacrificial anodes on the power unit should be inspected annually for replacement. See the Replacement Parts section for anode kit item numbers.

B. Winter Removal & Storage

- 1) Remove the fountain and lights from the pond before ice begins to form.
- 2) This is the perfect time to clean or power wash any debris on the unit before storing.
- 3) It is recommended to disconnect lights from the fountain and store in an area above freezing temperatures.

C. Spring Installation Inspection

- 1) Before re-installing the fountain and lights in the spring, check the condition of the power cord and quick disconnects, and replace any o-rings that may be cracked or missing.

Note

Contact your local Airmax Service Center for recommended annual preventative maintenance procedures.

5. Troubleshooting - Fountain

IF FOUNTAIN WILL NOT TURN ON

ISSUE	CORRECTION
GFCI Tripped	Reset GFCI
Power Cord Cut	Repair or replace power cord
Intake plugged	Clean intake
Timer not running	Check power to timer & battery back up
Not enough water in reservoir	Bring water level to appropriate minimum depth
Fountain impeller stuck	Remove fountain, clean or replace impeller
Breaker tripped due to overcurrent	Reduce current load on circuit, check other equipment
Breaker tripped to GFCI	Check overload and breaker
Fountain power cord wired improperly	Refer to control panel wiring manual.

IF NOZZLE HAS POOR QUALITY STREAMS

ISSUE	CORRECTION
Intake plugged	Clean intake
Not enough water in reservoir	Bring water level up to at least 48" at fountain
Debris caught in nozzle hole	Remove nozzle, clean, replace
Water coming over the float	Check fountain float for water

IF FOUNTAIN STARTS AND STOPS

ISSUE	CORRECTION
Intake plugged	Clean intake
Not enough water in reservoir	Bring water level up to minimum depth required

IF STREAMS RAISE AND LOWER

ISSUE	CORRECTION
Not enough water in reservoir	Bring water level up to minimum depth required
Water coming over the float	Check fountain float for water, replace if any

IF FOUNTAIN IS HUMMING - RUNNING

ISSUE	CORRECTION
Normal running	Nothing

IF FOUNTAIN IS HUMMING - NOT RUNNING

ISSUE	CORRECTION
Intake plugged	Clean intake
Voltage not high enough for starting	Make sure voltage at receptacle is correct
Fountain impeller stuck	Remove fountain, clean replace impeller
Motor running backwards	Check wiring/orientation of incoming power

* If your issue persists or is not covered in the troubleshooting guide above, please contact your Certified Airmax Service Technician to perform any troubleshooting measures you are uncomfortable with or unable to perform yourself. For fountain light set troubleshooting measures, please see the manual included with your light set.

7.5 HP Replacement Parts

654146 7.5 HP Power Unit, 460v 3 PH

1. 653359 Discharge Nut O-Ring
2. 653991 Nozzle Nut, Multi-Start
3. 654147 Discharge Horn Assembly with Nut, 7.5 - 10 HP
4. 654148 Discharge Hardware Kit, 7.5 - 10 HP
5. 654149 Pump Housing Hardware Kit
6. 654150 Impeller Hardware, 7.5 HP
7. 654152 Impeller Assembly with Hardware, 7.5 HP
8. 654154 Impeller Coupler, 7.5 -10 HP
9. 654156 Impeller Wear Ring with Hardware, 7.5 HP
10. 652219 Tie Down Ring
11. 654158 Upper Pump Housing, 7.5 - 10 HP
12. 654159 Pump Wall Insert Kit with Hardware, 7.5 - 10 HP
13. 654160 Motor Mount Hardware, 7.5 - 10 HP
14. 654161 Motor Mount, 7.5 - 10 HP
15. 654162 Motor Assembly, 7.5 HP 460v 3 PH
16. 654163 4 Pin Motor Lead, 48"
17. 654164 Lower Pump Housing with Hardware, 7.5 - 10 HP
18. 654165 Intake Basket Mounting Hardware
19. 653112 Intake Extension with Hardware
20. 654166 Motor Brace with Hardware, 7.5 - 10 HP
21. 653111 Intake Bottom Plate with Hardware
22. 654167 Intake Basket Assembly, 7.5 - 10 HP
23. 654168 Sacrificial Anode Kit, 7.5 - 10 HP *Not Shown

10 HP Replacement Parts

654177 10 HP Power Unit 460v 3 PH

1. 653359 Discharge Nut O-Ring
2. 653991 Nozzle Nut, Multi-Start
3. 654147 Discharge Horn Assembly with Nut, 7.5 - 10 HP
4. 654148 Discharge Hardware Kit, 7.5 - 10 HP
5. 654149 Pump Housing Hardware Kit, 7.5 - 10 HP
6. 654150 Impeller Hardware, 7.5 - 10 HP
7. 654178 Impeller Assembly with Hardware, 10 HP
8. 654154 Impeller Coupler, 7.5 - 10 HP
9. 654180 Impeller Wear Ring with Hardware, 10 HP
10. 652219 Tie-Down Ring
11. 654158 Upper Pump Housing, 7.5 - 10 HP
12. 654159 Pump Wall Insert Kit with Hardware, 7.5 - 10 HP
13. 654160 Motor Mount Hardware, 7.5 - 10 HP
14. 654161 Motor Mount, 7.5 - 10 HP
15. 654183 Motor Assembly, 10 HP 460v 3 PH
16. 654163 4-Pin Motor Lead, 48"
17. 654164 Lower Pump Housing with Hardware, 7.5 - 10 HP
18. 654165 Intake Basket Mounting Hardware
19. 653112 Intake Basket Extension with Hardware
20. 654166 Motor Brace with Hardware, 7.5 - 10 HP
21. 653111 Intake Bottom Plate with Hardware
22. 654167 Intake Basket Assembly, 7.5 - 10 HP
23. 654168 Sacrificial Anode Kit, 7.5 - 10 HP *Not Shown

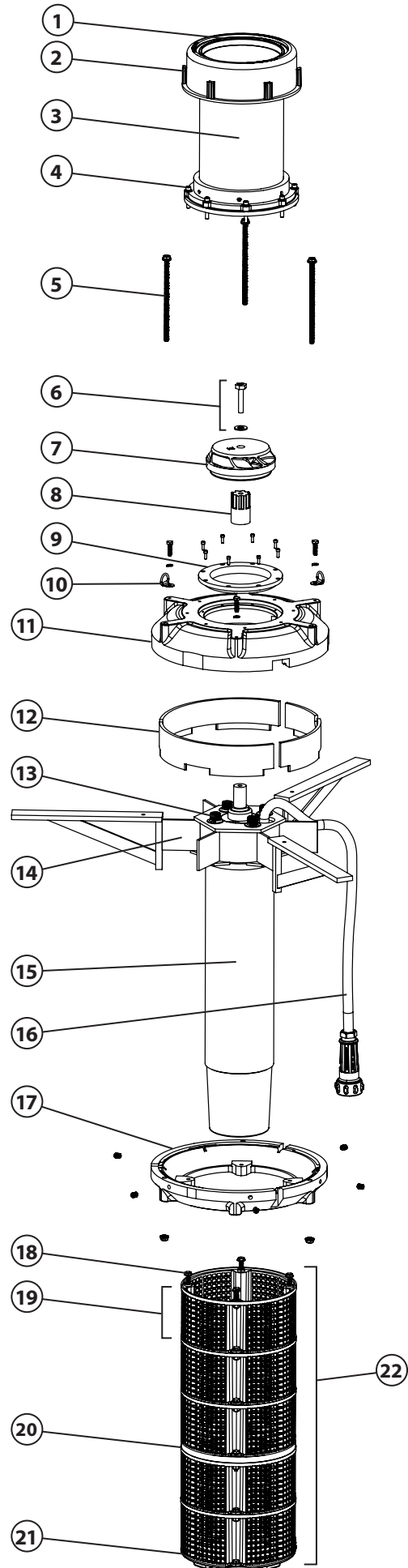

LakeSeries Twin ISP Float

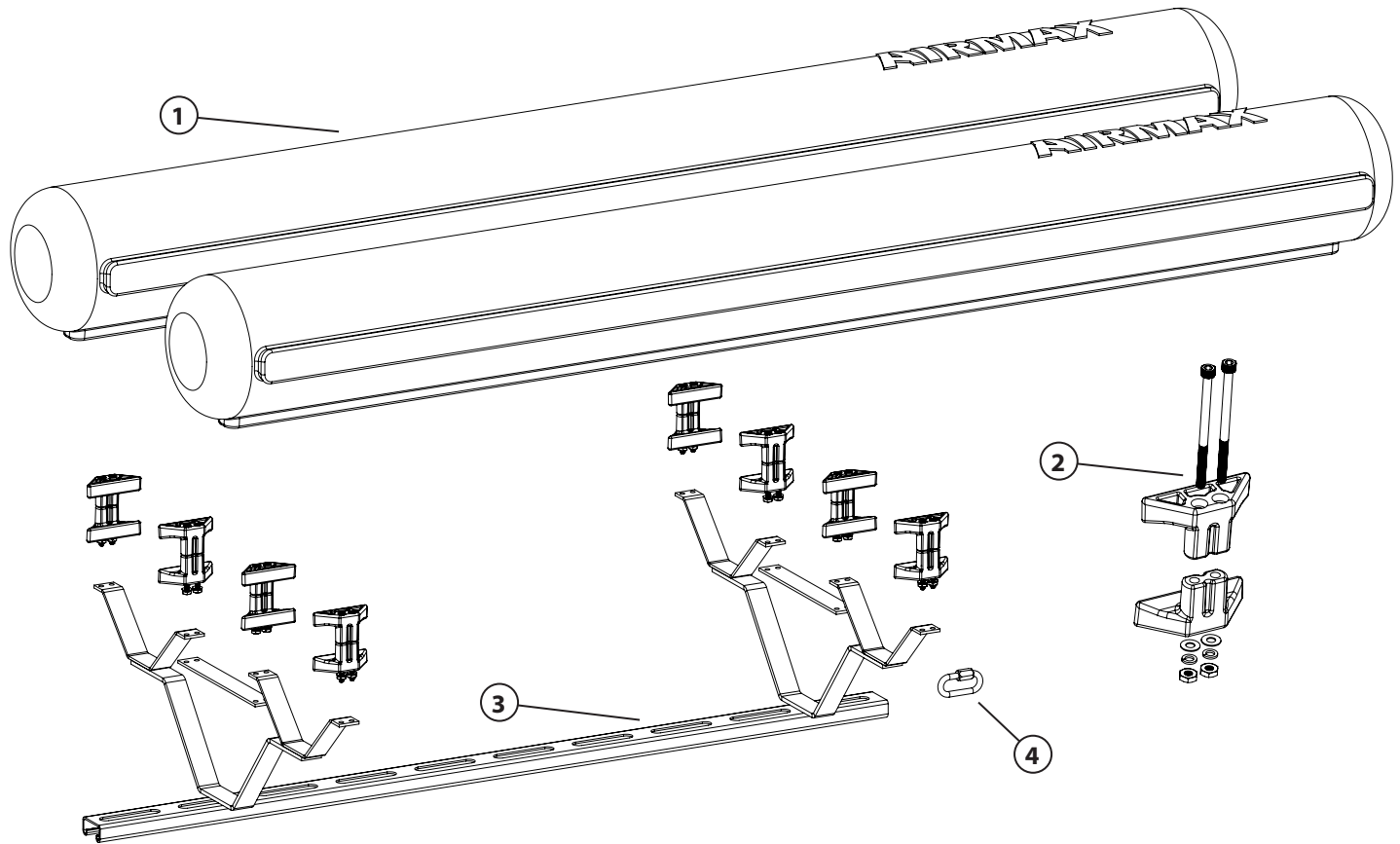
**654169 Airmax LakeSeries Float Kit - Twin ISP Floats**

1. 651557 Airmax LakeSeries Float 60"
2. 652200 Airmax LakeSeries Float Clamp Assembly (4 pk)
3. 654171 Airmax LakeSeries Float Support Assembly - Twin ISP Floats
4. 654172 Airmax Mooring Cable Connecting Link (3 pk)

Airmax, Inc.

Airmax LakeSeries Fountain

Limited Warranty

Airmax, Inc. warrants to the original purchaser (the end user) of any Airmax LakeSeries Fountain manufactured by Airmax, Inc. that any component which proves to be defective in materials or workmanship, as determined by the factory within 5 years from the original purchased date, will be repaired or replaced at no charge with a new or remanufactured part, and returned freight prepaid. The end user shall assume all the responsibility and expense for removal, packaging, and freight to ship to Airmax, Inc. to determine the warranty claim and for all reinstallation expenses.

The warranty is void in cases where damage results from: improper installation, improper electrical connection, improper voltage, alteration, lightning, careless handling, misuse, abuse, disassembly of motor or failure to follow maintenance or operating instructions. Modification or repair by an unauthorized repair facility will void the warranty.

In no case will Airmax, Inc. or its dealers accept responsibility for any costs incurred by the user during installation, removal, inspection, evaluation, repair, parts replacement, or for return freight. Nor will any liability be accepted for loss of use, loss of profits, loss of goodwill, for consequential damage, or for personal injuries to the purchaser or any person.

In the event of problems believed to be covered under warranty, it will be necessary to notify the dealer who will try to help resolve the problem and who may contact the factory for additional assistance. If it is concluded that there may be a defect which may be covered under warranty, it will be necessary to get a Return Material Authorization (RMA) from the dealer before shipment. Freight collect shipments will not be accepted by the factory on warranties or repairs.

The product or part(s) must be returned freight prepaid, to the factory, as directed, and in its original packaging or in a container which will prevent damage. Parts returned under warranty and damaged during shipping will not be covered under warranty for the shipping damage. If the factory evaluation of the returned goods concludes that the failure is due to defects in materials or workmanship, the part or parts in question will be replaced under warranty with new parts, remanufactured parts, or will be repaired at the factory's option. The warranty period for all parts supplied under warranty will terminate at the end of the original product's warranty. All warranty shipments from the factory will be shipped freight prepaid.

Warranty registration is HIGHLY recommended.

No implied warranties of any kind are made by Airmax, Inc. for its products, and no other warranties, whether expressed or implied, including implied warranties of merchantability and fitness for a particular purpose, shall apply. Should an Airmax, Inc. product prove to be defective in materials or workmanship, the retail purchaser's sole remedy shall be repair or replacement of the product as expressly provided above.

The manufacturer's warranty will begin from the dealer's original purchase date if the product is not registered. To register a product, you are required to fill out the warranty registration form at airmaxeco.com/warranty. Warranty registration must be submitted directly to Airmax within 30 days of the end-user's purchase date.



2 HP Gusher

10 HP Gusher

5 HP Gusher



Classic Pattern



Crown and Trumpet Pattern



Trumpet Pattern

For Information on Spray Patterns,
Visit Us Online at airmaxeco.com

Airmax, Inc.

15425 Chets Way Street
Armada, MI 48005

(866) 4-AIRMAX
airmaxeco.com