

INSTALLATION INSTRUCTIONS



Item #653945 - 2 HP 460v
#653946 - 3 HP 460v
#653947 - 5 HP 460v



Table of Contents:

Important Information	2	Timer Maintenance & Operation	10-11
2 - 5 HP 460v Contents & Installation	3-6	Warranty Information	12
2 - 5 HP 460v Wiring Diagrams	7-9		

IMPORTANT INFORMATION:

Please read these instructions thoroughly before use. Failure to follow instructions may result in equipment damage or failure, losses, injury or death.

Electrical connections to the control panel and proper grounding (properly sized copper conductor from the grounding terminal to the service panel or grounding rod) are to be completed by a licensed electrician and in accordance with the National Electric Code, local codes or ordinances.

WARNING:

To reduce the risk of electric shock or injury:

- Install only on a circuit protected by a Ground Fault Circuit Interrupter (GFCI). ALWAYS install an acceptable safety shut-off switch between the main power source and control panel.
- DO NOT operate the control panel if electrical cords are broken or spliced.
- ALWAYS turn off electrical power before installing, removing or servicing the control panel components.
- Control panels must be installed a minimum of 300 mm (12 in.) above the electrical datum plane.
- This control panel is NOT intended for use in swimming areas, or other situations where bodily contact is made with the water. Although the control panel is designed for outdoor use, it should never be submerged in water.

CAUTION:

To reduce the risk of equipment damage or failure:

- The control panel is NOT submersible; do not place the timer where it might contact or fall into the water.
- DO NOT operate the control panel with a unit that exceeds the maximum voltage indicated by the control panel specifications. Operating with a unit larger than recommended can cause damage to the control panel and will NOT be covered under warranty.

IMPORTANT: Airmax is not responsible for equipment damage or failure, losses, injury or death resulting from failure to follow safety precautions, misuse or abuse of equipment.

TECHNICAL SPECIFICATIONS:

ITEM NUMBER	VOLTAGE	PANEL DIMENSIONS	MOUNTING DIMENSIONS
653945	2 HP 460v	16" w x 17 ¾" h x 8 ½" d	12" w x 18 ½" h
653946	3 HP 460v	16" w x 17 ¾" h x 8 ½" d	12" w x 18 ½" h
653947	5 HP 460v	16" w x 17 ¾" h x 8 ½" d	12" w x 18 ½" h

2 HP 460v PRODUCT CONTENTS:



Airmax 460v Control Panel 2 HP

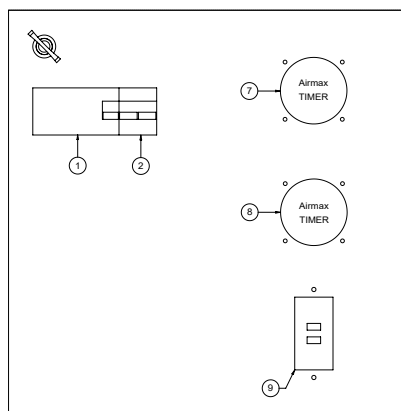
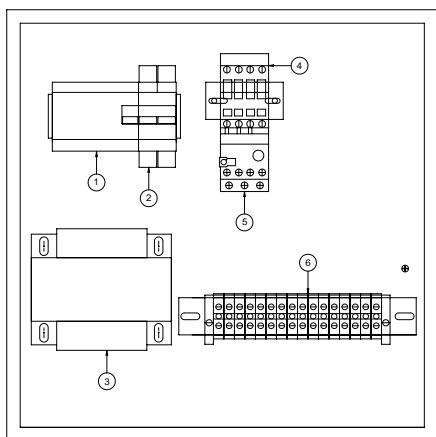

2 HP 460v REPLACEMENT PARTS:

ITEM	DESCRIPTION	PART #	ITEM	DESCRIPTION	PART #
1	Motor GFCI Breaker (25 Amp)	652207	6	Screw Clamp Feed-Through Kit	651781
2	Control Breaker (3 Amp)	652208	7	Motor Timer	651112
3	Transformer	652209	8	Light Timer	651112
4	2 - 5 HP Contactor	651962	9	Light GFCI	651952
5	2 HP Overload Relay	652205			

3 HP 460v PRODUCT CONTENTS:



Airmax 460v Control Panel 3 HP

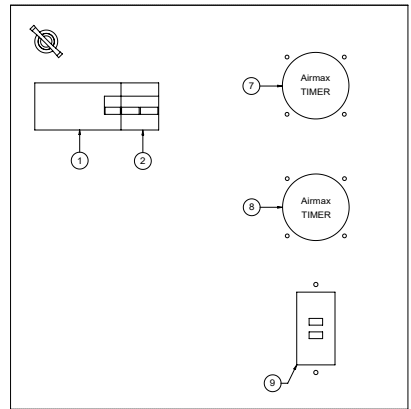
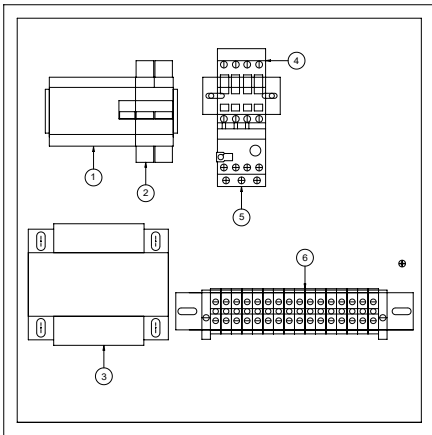

3 HP 460v REPLACEMENT PARTS:

ITEM	DESCRIPTION	PART #	ITEM	DESCRIPTION	PART #
1	Motor GFCI Breaker (25 Amp)	652207	6	Screw Clamp Feed-Through Kit	651781
2	Control Breaker (3 Amp)	652208	7	Motor Timer	651112
3	Transformer	652209	8	Light Timer	651112
4	2 - 5 HP Contactor	651962	9	Light GFCI	651952
5	3 HP Overload Relay	652206			

5 HP 460v PRODUCT CONTENTS:



Airmax 460v Control Panel 5 HP

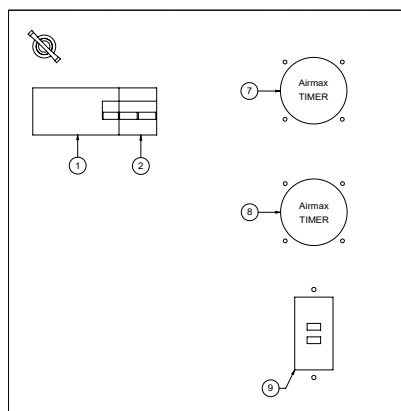
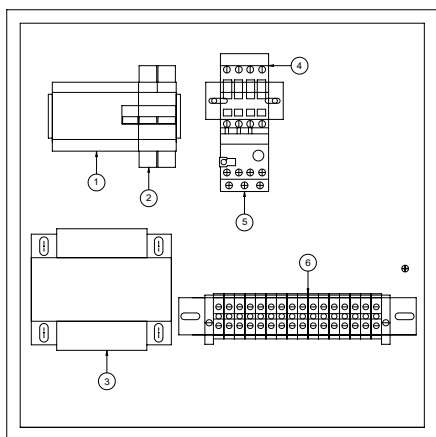

5 HP 460v REPLACEMENT PARTS:

ITEM	DESCRIPTION	PART #	ITEM	DESCRIPTION	PART #
1	Motor GFCI Breaker (25 Amp)	652207	6	Screw Clamp Feed-Through Kit	651781
2	Control Breaker (3 Amp)	652208	7	Motor Timer	651112
3	Transformer	652209	8	Light Timer	651112
4	2 - 5 HP Contactor	651962	9	Light GFCI	651952
5	5 HP Overload Relay	651883			

2 HP, 3 HP & 5 HP 460v INSTALLATION INSTRUCTIONS:

Airmax Control Panels are designed for outdoor use but should be mounted above any high water levels. Holes should be drilled into the bottom of the control panel for electrical access. We recommend using grommets to protect and seal the electrical access points and to help keep the control panel clean.

It is recommended that you have between 460 and 495 combined volts on any two of your incoming terminals (L1-L2, L1-L3, or L2-L3). Excessively high or excessively low voltage could cause potential harm to the control panel or motor components.

CONNECTING ELECTRICAL WIRING:

CONNECT UNIT TO CONTROL PANEL

⚠ WARNING: ⚠

Turn off electrical power before connecting units to the control panel.

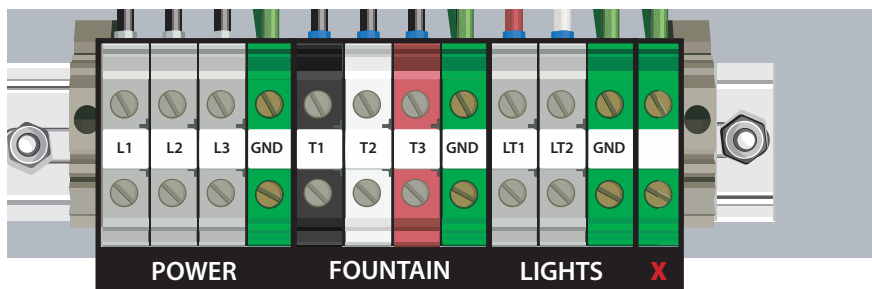

Connect to a Fountain:

- **Black** lead to **T1** on the terminal strip
- **White** lead to **T2** on the terminal strip
- **Red** lead to **T3** on the terminal strip
- **Green** lead to the **grounding terminal**

Connect to Fountain Lights (optional):

- **Black** lead to **LT1** on the terminal strip
- **White** lead to **LT2** on the terminal strip
- **Green** lead to the **grounding terminal**

CONNECT CONTROL PANEL TO POWER SOURCE

Connect the following:

- **Line 1** to **L1** on the terminal strip
- **Line 2** to **L2** on the terminal strip
- **Line 3** to **L3** on the terminal strip
- **Green** lead to the **grounding terminal**
- Set or verify that the overload assembly in the control panel is set to the motor nameplate value.

Checking Incoming Control Panel Wiring for Correct Motor Rotation:

Once all incoming power has been provided for the Airmax 3-phase control panel, one final check for proper motor rotation is key to a successful installation. Using a 3-Phase Sequence Rotation Tester will save time on site. Follow the steps below to check 3-phase wiring.

3-Phase Sequence Rotation Tester
(Airmax Item # 650941)

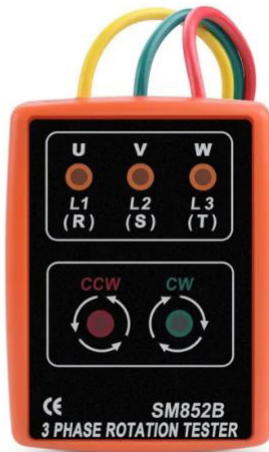

Step 1: Leave all breakers and timers inside the control panel in the OFF position. There is no need to send power to the motor at this time.

Step 2: Turn the power ON at the main power source (external shut-off switch or main breaker panel).

Step 3: Hold each lead (L1, L2 & L3) from the sequence rotation tester to the corresponding incoming terminals on the Airmax control panel.

Step 4: Check the indicator light on the meter.

- a) If the CW (clockwise) indicator is lit, your incoming wiring sequence should be correct.
- b) If the CCW (counterclockwise) indicator is lit, turn the MAIN POWER to the OFF position. This is an indication that the incoming wiring sequence must be adjusted.

NOTE: Airmax 460v 3-phase control panels must register CW (clockwise) on the meter at the control panel since the rotation is converted to the counterclockwise rotation at the motor. A reading of CCW at the control panel would mean that the motor is spinning clockwise and would not produce a pattern.

When calculating the most effective wiring sequence, Steps 5a – 5e should be carried out by a qualified electrician. This process should be used on ALL 3-phase installations to achieve the greatest efficiency, even if the motor rotation is initially correct.

Step 5: Calculating 3-Phase Amperage Imbalance: Follow the procedure below to determine which sequence will help produce not only the correct rotation, but also the most efficient operation of the motor. Identifying the sequence with the lowest imbalance will improve motor efficiency and lessen the possibility of nuisance trips.

Wire color coding on incoming leads may vary by site, but if all wires are colored the same, temporarily label them with electrical tape as L1, L2 and L3, if necessary, to avoid confusion when testing.

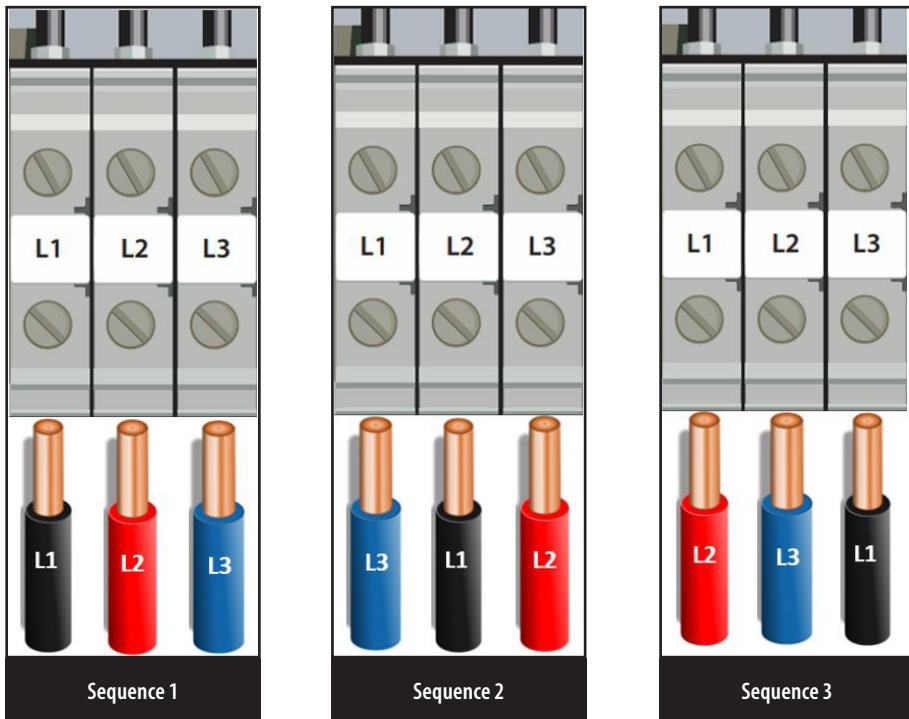

a) Turn the main power ON, turn the fountain breakers ON, and turn the motor timer to MANUAL ON. Check and record amps on T1, T2, & T3 using a clamp voltmeter.

NOTE: ALWAYS use the fountain power cord wires when checking amperage for this test.

b) REPEAT the process making sure to turn the main power source to OFF each time before changing the wiring sequence.

Sequence 1	Sequence 2	Sequence 3
T1 = 8.2 Amps	T1 = 8.0 Amps	T1 = 8.0 Amps
T2 = 7.4 Amps	T2 = 7.7 Amps	T2 = 7.8 Amps
T3 = 8.4 Amps	T3 = 8.3 Amps	T3 = 8.2 Amps

c) Add up all three readings from Sequence 1 and divide by 3 to get the average.

T1	8.2 Amps	Average 8 Amps
T2	7.4 Amps	
T3	8.4 Amps	
24 Amps ÷ 3		

Calculate the greatest amperage difference from the average:

$$8 \text{ amps} - 7.4 \text{ amps} = 0.6 \text{ amps}$$

Divide this difference by the average to calculate the % of imbalance:

$$0.6 \text{ amps} \div 8 = 7.5\% (0.075) \text{ imbalance on Sequence 1}$$

d) Next, add up all three readings from Sequence 2 and use the same process to calculate the imbalance

T1	8 Amps	Average 8 Amps
T2	7.7 Amps	
T3	8.3 Amps	
24 Amps ÷ 3		

Calculate the greatest amperage difference from the average:

$$8 \text{ amps} - 7.7 \text{ (or } 8.3) \text{ amps} = 0.3 \text{ amps}$$

Divide this difference by the average to calculate the % of imbalance:

$$0.3 \text{ amps} \div 8 = 3.5\% (0.0375) \text{ imbalance on Sequence 2}$$

e) Next, add up all three readings from Sequence 3 and use the same process to calculate the imbalance

T1	8 Amps	Average 8 Amps
T2	7.8 Amps	
T3	8.2 Amps	
24 Amps ÷ 3		

Calculate the greatest amperage difference from the average:

$$8 \text{ amps} - 7.8 \text{ (or } 8.2) \text{ amps} = 0.2 \text{ amps}$$

Divide this difference by the average to calculate the % of imbalance:

$$0.2 \text{ amps} \div 8 = 2.5\% (0.025) \text{ imbalance on Sequence 2}$$

Step 6: Based on the percentage of imbalance, Sequence 3 should be the best wiring orientation since it has the lowest imbalance %, and the motor shaft should be spinning counterclockwise, producing the best spray pattern..

Step 7: Finally, we recommend writing the correct wiring sequence inside the control panel on the Install Data Sticker.

For more information and technical specs, visit our Airmax LakeSeries Fountain web page. Please contact Airmax Technical Support at 866-424-7629 or feel free to email us at contactus@airmaxeco.com should you have any questions regarding incoming power sequencing for Airmax 3-phase fountains.

2 HP 460v CONTROL PANEL WIRING DIAGRAM:

- Main Disconnect Supplied and Installed by Licensed Electrician
- Input Hubs Must Comply With UL 514B
**Shall Be Provided By Installer*

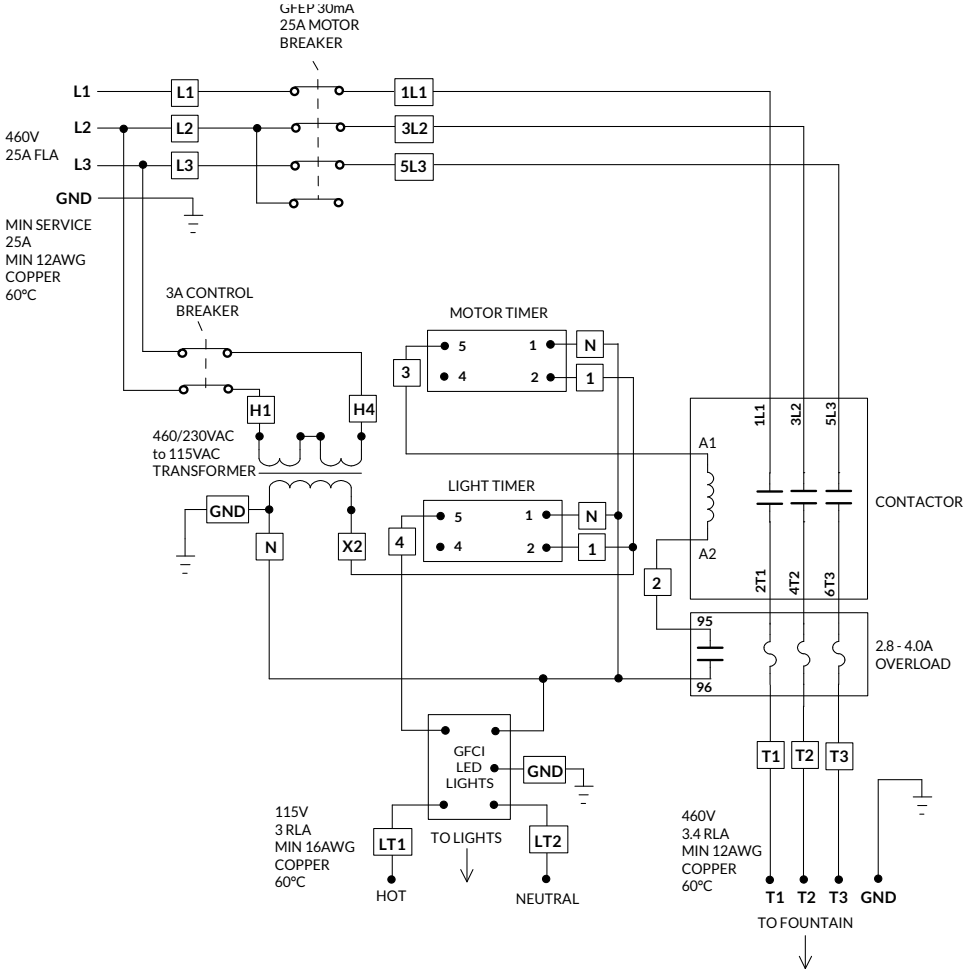

3 HP 460v CONTROL PANEL WIRING DIAGRAM:

- Main Disconnect Supplied and Installed by Licensed Electrician
- Input Hubs Must Comply With UL 514B
**Shall Be Provided By Installer*

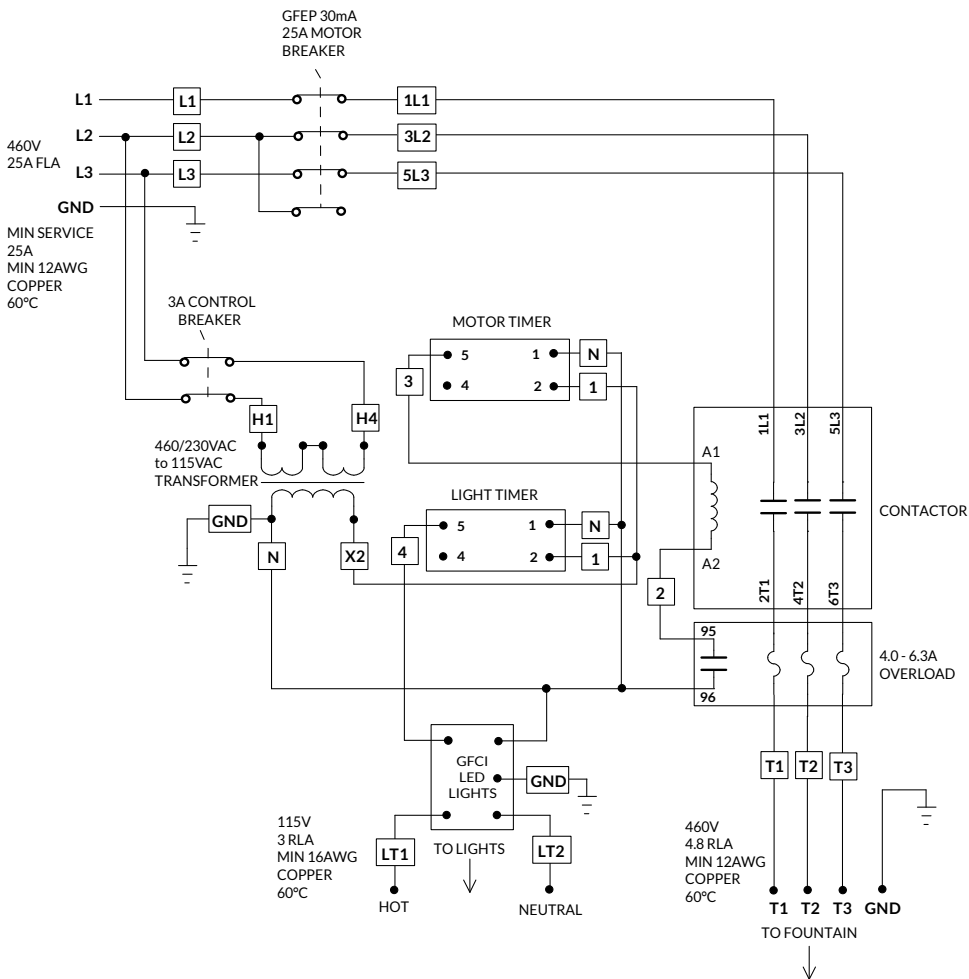

5 HP 460v CONTROL PANEL WIRING DIAGRAM:

- Main Disconnect Supplied and Installed by Licensed Electrician
- Input Hubs Must Comply With UL 514B
**Shall Be Provided By Installer*

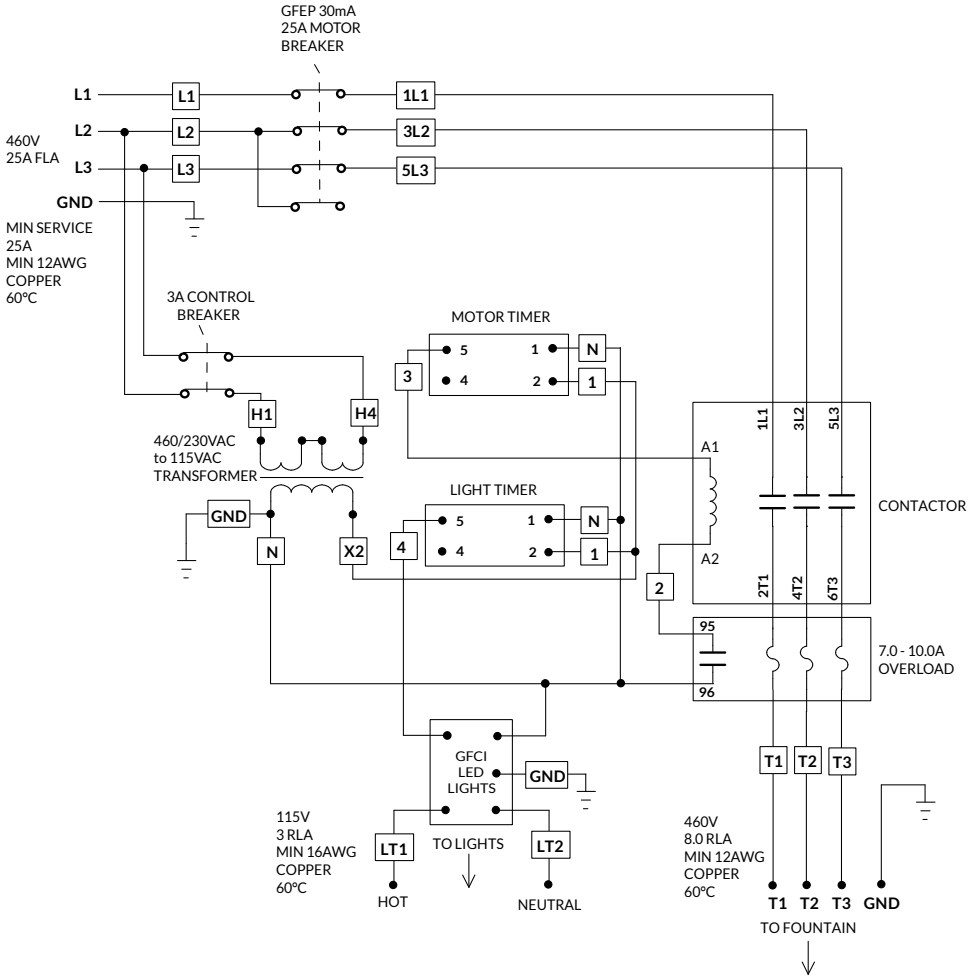

Maintenance & Operation of the Control Panel Timer:

RUN TIME USING THE MANUAL BYPASS

Press the MANUAL button until the line is above "ON". This mode will bypass all programmed settings. The MANUAL/ON mode can be used if 24/7 operation is desired.

RUN TIME USING A PROGRAM

Setting the Clock

- Step 1:** Press the RESET button to clear all history from memory.
- Step 2:** Press and hold the CLOCK button.
- Step 3:** Continue to hold the CLOCK button while pressing the DAY, HOUR or MIN button to set the day and time.
- Step 4:** Release the CLOCK button.



Reset Button

CREATING A PROGRAM

The Airmax Digital Timer allows up to 8 ON/OFF run times.

Select the days for each run time to occur based on the 15 preset schedule of days shown in the table. (Fig. 1 - Page 11)

Note: Ponds will receive the most benefit from continual water movement. We recommend running fountains at least 8-10 hours daily to maximize benefits, unless a secondary aeration system is in operation.

- Step 1:** Press the TIMER button once to display "1 on --:--"
- Step 2:** Press the DAY button to scroll through the preset schedule options. *Mode A, MONDAY - SUNDAY, is the default schedule.*
- Step 3:** When the desired schedule is displayed, press the HOUR or MIN buttons to select the ON time.
- Step 4:** Press the TIMER button once to switch display to "1 off --:--" Programming without inserting an OFF time will also allow the fountain to run 24/7 if desired.
- Step 5:** Press the DAY button to scroll to the program selected in step 2.
- Step 6:** Press the HOUR or MIN button to select the OFF time.
- Step 7:** Repeat steps 1-6 for each additional program desired, up to 8 programs.
- Step 8:** When all programs have been created press the CLOCK button to execute the programs.
- Step 9:** Press the MANUAL button until the line is above AUTO.

Maintenance & Operation of the Control Panel Timer Cont.:

		DAYS FOUNTAIN IS RUNNING							
PRESET MODES	a.	MO	TU	WE	TH	FR	SA	SU	
	b.	MO							
	c.		TU						
	d.			WE					
	e.				TH				
	f.					FR			
	g.						SA		
	h.							SU	
	i.	MO	TU	WE	TH	FR			
	j.						SA	SU	
	k.	MO	TU	WE	TH	FR	SA		
	l.	MO	TU	WE					
	m.				TH	FR	SA		
	n.	MO		WE		FR			
	o.		TU		TH		SA		

Fig. 1

EDITING A PROGRAM

Review a Program – To review the list of current programs, press the TIMER button repeatedly to scroll through the programs. When finished press the CLOCK button to return to the time of day.

Change an On/Off Time – To adjust an On/Off time, press the TIMER button to scroll to the program you want to change. Press the DAY, HOUR or MIN buttons to adjust the time. When finished press the CLOCK button to return to the time of day.

Add a Program – If there are not already 8 programs running, you may elect to add an additional program by following the CREATING A PROGRAM procedure.

Remove a Program – In the event that a program needs to be removed, you will need to RESET the timer and program only the desired schedules.

REPLACING THE BATTERY

Note: Timer settings will be retained for approximately 1 minute once the battery is removed. Each timer uses (1) CR2032 Lithium Battery.

Step 1: On the back of the timer, use a small flathead screwdriver or similar to pull the battery compartment from the timer.

Step 2: Install a new battery (print side down) and reinstall the battery compartment.

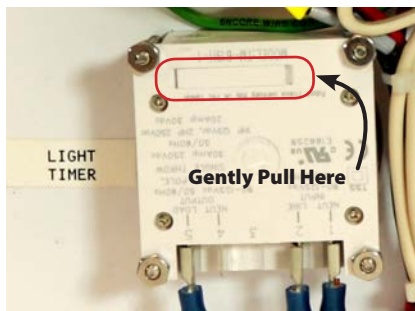

WARRANTY:

Airmax Control Panels are covered under the system warranty
(3 Years - EcoSeries & PondSeries / 5 Years - LakeSeries)

THANK YOU FOR CHOOSING:

Airmax, Inc.

15425 Chets Way Street, Armada, MI 48005
866-424-7629 | www.airmaxeco.com | contactus@airmaxeco.com

#653899 V2